

CHECKFIRE 210 DETECTION AND ACTUATION SYSTEM

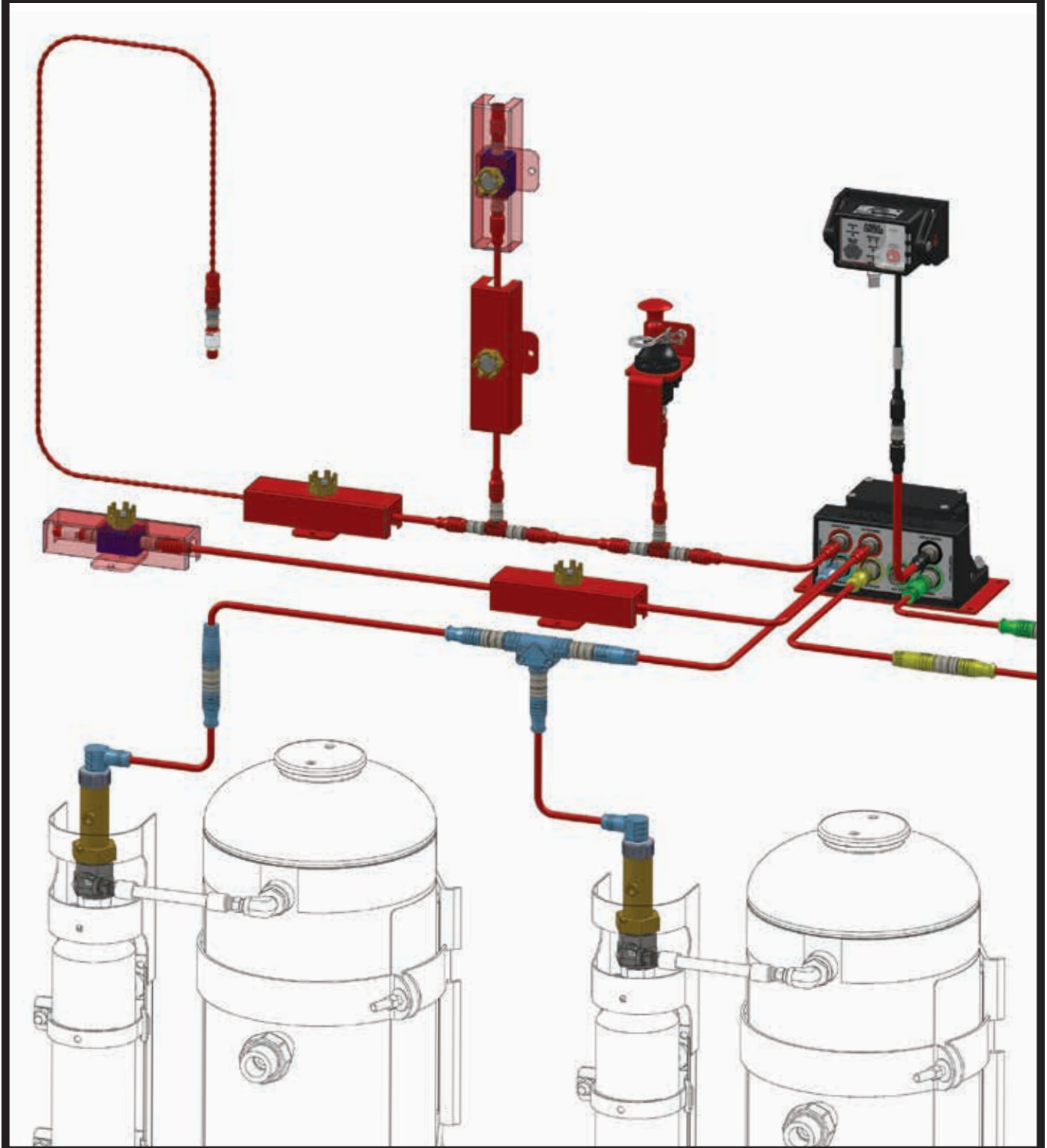

PLANNING, INSTALLATION, PROGRAMMING, OPERATION, AND MAINTENANCE MANUAL



This manual is intended for use with the ANSUL® CHECKFIRE 210 Detection and Actuation System. This system is specifically engineered for monitoring and release of vehicle/equipment fire suppression systems. Planning, installation, programming, operation, and maintenance of the system must conform to the limitations detailed in this manual. Installation and maintenance shall be performed by an individual holding current ANSUL Certification from an ANSUL CHECKFIRE 210 Training Program with training to plan, install, recharge, and maintain the CHECKFIRE 210 System(s). Individuals must also hold current ANSUL Certification from an ANSUL A-101 or LVS training program.

Those who plan, install, program, operate, reset, inspect, or maintain these systems should read this entire manual. Specific sections will be of particular interest depending upon one's responsibilities.

As with all electro-mechanical-pneumatic equipment, the system needs periodic care to provide maximum assurance that it will operate effectively and safely. Inspection frequency shall be performed consistently, depending on operating and/or environmental conditions. Maintenance shall be performed semi-annually, or more frequently, depending on operating and/or environmental conditions.

The application and use of the CHECKFIRE 210 System is limited to the applications and uses described in this manual. For other applications, contact your Authorized ANSUL Distributor, Territory Manager, or Tyco Fire Protection Products – Technical Services Department, Marinette, Wisconsin 54143-2542, USA.

Note: The converted metric values in this manual are provided for dimensional reference only and do not reflect an actual measurement.

- ▶ Part Number: 440392-01
- ▶ Date: 2014-MAY-09

ANSUL, CHECKFIRE, and the product names listed in this material are marks and/or registered marks. Unauthorized use is strictly prohibited.



DANGER

Indicates a hazardous situation in which a person **will experience serious personal injury or death** if the situation is not avoided.



WARNING

Indicates a hazardous situation in which a person **could experience serious personal injury or death** if the situation is not avoided.



CAUTION

Indicates a hazardous situation in which a person **could experience minor or moderate personal injury** if the situation is not avoided.

CAUTION

Addresses practices not related to personal injury, such as a system part malfunctioning, property damage, or system failure.

NOTICE

Addresses general practices or observations related to system function that are *not* related to personal injury.

REVISION RECORD

PAGE 2 REV. 0 2014-MAY-09

*CHECKFIRE 210
Detection and Actuation System*

NOTES:

<u>SECTION</u>	<u>PAGES</u>	<u>SECTION</u>	<u>PAGES</u>
1 SYSTEM DESCRIPTION	1-1 – 1-4	3 USER INTERFACE	3-1 – 3-8
System Description	1-1	User Interface	3-1
2 COMPONENTS	2-1 – 2-14	Field Connectivity	3-1
CHECKFIRE 210 Display Module	2-1	Display Module Front Panel Buttons	3-1
CHECKFIRE 110/210 Mounting Bracket	2-1	Display Module Front Panel Indicators	3-4
Display Cable	2-2	Internal Sounder	3-5
Display Cable Bulkhead Connector	2-2	Display Module Mounting	3-5
CHECKFIRE 210 Interface Control Module	2-3	Power	3-5
CHECKFIRE 210 ICM Battery Module	2-3	Interface Control Module	3-6
Electric Manual Actuator (EMA)	2-4	4 SYSTEM PLANNING	4-1 – 4-12
Electric Manual Actuator Bracket	2-4	Hazard Identification Basic Planning	4-1
Optional Pneumatic Manual Actuator	2-4	Specific Planning Information	4-2
Spot Thermal Detector	2-5	Planning Checklist Template	4-11
Spot Thermal Detector Bracket and Heat Shield	2-5	5 INSTALLATION AND PROGRAMMING	5-1 – 5-38
Linear Detector	2-5	Installation	5-1
Detection Circuit Cable	2-6	CHECKFIRE 210 Display Module Installation	5-1
Detection Circuit Bulkhead Connector	2-6	Mounting Interface Control Module	5-4
Detection Circuit Tee	2-6	Cable Connectivity/Installation	5-5
Detection Circuit EOL (End of Line) Device	2-6	Linear Detector Installation	5-7
Detection Circuit Branch Terminator	2-6	Spot Thermal Detector Installation	5-8
Release Circuit Cable	2-7	Electric Manual Actuator (EMA) Installation	5-9
Release Circuit Tee	2-7	Electric - Pneumatic Actuator Installation	5-11
Release Circuit Drop Cable	2-7	Detection Circuit Cables	5-12
Release and Power Circuits Bulkhead Connector	2-7	Display Cables	5-14
Release Circuit Terminator	2-7	Release Circuit Cables	5-14
Electric-Pneumatic Actuator	2-8	Relay Circuit Cables	5-15
Protracting Actuation Device (PAD)	2-8	Auxiliary Output Cables	5-16
Backup Power/Relay Circuit Cable	2-9	Power Circuit Cables	5-16
Auxiliary Power Cable	2-9	Discharge Pressure Switch	5-17
Power Circuit Cable	2-10	Label Package	5-19
Fused Power Circuit Cable	2-10	Final Component Connections	5-20
Release and Power Circuits Bulkhead Connector	2-10	Programming	5-20
Label Package	2-11	Table 5-1: Programming Summary	5-21
Discharge Pressure Switch Assembly	2-12	Table 5-2: Preparation –ICM Manual Programming Mode	5-22
Detection Circuit Tester	2-13	Table 5-3: Manual Programming Options	5-24
Release Circuit Tester	2-13	Table 5-4: Download Event History Log	5-30
Release Circuit Test Plug	2-13	Table 5-5: Personal Computer (PC) Options	5-32
		Event History Log - Programming	5-37

<u>SECTION</u>	<u>PAGES</u>
6 OPERATIONAL TEST AND PLACE IN SERVICE	6-1 – 6-22
Table 6-1: Preparation – Operational Test	6-1
Table 6-2: Isolation Feature	6-4
Table 6-3: Operational Test	6-6
Table 6-4: Internal Power Only – Operational Test	6-17
Table 6-5: Alarm Condition LED Indicators	6-18
Table 6-6: Placing CHECKFIRE 210 System in Service	6-19
7 IN CASE OF FIRE	7-1 – 7-2
In Case of Fire	7-1
8 RECHARGE, INSPECTION, AND MAINTENANCE	8-1 – 8-8
Recharge	8-1
Inspection and Maintenance	8-3
Daily Inspections	8-3
Maintenance	8-3
Five-Year PAD Replacement	8-6
Table 8-1: Event History Messages	8-7
9 TROUBLESHOOTING	9-1 – 9-12
Troubleshooting	9-1
Table 9-1: Power LED Indications	9-1
Table 9-2: Release LED Indications	9-3
Table 9-3: Detection LED Indications	9-4
Table 9-4: Insolate Mode	9-5
Table 9-5: Multiple Amber LED Indications	9-5
Table 9-6: No LED Indications	9-6
Table 9-7: Specific Circuit Testing Procedures	9-7
10 APPENDIX	10-1 – 10-4
Component Index	10-1
Cable and Bulkhead Dimensions	10-2
Linear Detector Fluid Resistance Capability	10-3
Chemical Resistant Chart	10-4

SYSTEM DESCRIPTION

The CHECKFIRE 210 Detection and Actuation System is typically used with an ANSUL A-101 or LVS Vehicle Fire Suppression System for 24-hour protection of equipment. The system is designed for vehicles/equipment in extreme environmental and physical conditions.

Industries Where Vehicles Use CHECKFIRE 210 Systems:

- Forestry
- Agriculture
- Construction
- Public transportation
- Public utilities
- Land fills
- Waste disposal
- Mining

The automatic detection and actuation system provides two monitored input circuits and one monitored output circuit to activate an ANSUL fire suppression system. On detecting a fire condition, the system activates the release circuit resulting in the discharge of an expellant gas cartridge initiating fire suppression system operation. Optional pneumatic actuation is available.

CHECKFIRE 210 System Features

- Supervised power, detection, release, and communication circuits
- System may be powered by internal battery and/or external power
- Two time delays programmable to 0, 5, 10 or 15 seconds
- “DELAY/Reset/Silence” button
- “PUSH To Activate / Alarm When Lit” electric manual activation button and LED
- Color-coded “Plug and Play” connections
- 85 dB internal sounder
- Dust and water tight (IP67 rated)
- Manual programming button
- Computer programmable via mini USB port
- Two analog detection circuits, detection circuit #2 may be programmed for pressure switch feedback
- Detection circuits are programmable for independent detection and release, cross-zone detection and release or detection only
- Auxiliary Power output available when external power is connected
- Two internal programmable SPDT Form “C” relays (5A @ 30 VDC automotive)
- Isolate switch
- Downloadable 4000+ Event History Log

CHECKFIRE 210 System Specifications

SYSTEM POWER (24 HOUR OPERATION)

Supervised internal 3.6 VDC power source

Connection for 12/24 VDC external power source when required

SYSTEM CURRENT DRAW*

Nominal 6 mA @ 10.2 VDC

• Maximum Alarm/Fault 80 mA @ 10.2 VDC

Nominal 6 mA @ 28.0 VDC

• Maximum Alarm/Fault 35 mA @ 28.0 VDC

*Does not include AUX OUTPUT load of up to 1.5 A

OPERATING TEMPERATURE LIMITS

– 40 °F to 185 °F (– 40 °C to 85 °C)

APPROVALS

FM Approved and CE Marked

CHECKFIRE 210 System Connectivity

The CHECKFIRE 210 Display Module (see Figure 1-1) communicates with the CHECKFIRE 210 Interface Control Module (ICM) through the Display Cable. The black color-coded connector securely attaches to the ICM receptacle using threaded circular connectors.



FIGURE 1-1
CHECKFIRE 210 DISPLAY MODULE

009272

CHECKFIRE 210 System Connectivity (Continued)

The CHECKFIRE 210 ICM provides receptacles for the following circuits; refer to Figure 1-2.

DETECTION INITIATING / MANUAL ACTIVATION CIRCUITS

Two **Red** Color-coded detection receptacles:

Detection Circuit #1 receptacle connects to:

- Detection Circuit Cable(s)
- Electric Manual Actuator(s)
- Linear Detector(s)
- Spot Thermal Detector(s)

Detection Circuit #2 receptacle connects to:

- Detection Circuit Cable(s)
- Electric Manual Actuator(s)
- Linear Detector(s)
- Spot Thermal Detector(s)
- Discharge Pressure Switch (if programmed for pressure switch feedback)

DISPLAY MODULE CIRCUIT

Black color-coded receptacle connects to:

- Display Cable(s)

RELEASE CIRCUIT

Blue color-coded receptacle connects to:

- Release Circuit Cable(s)

RELAY #1 AND #2 CIRCUIT (Optional)

Yellow color-coded receptacle connects to:

- Relay Circuit Cable(s)

AUXILIARY OUTPUT CIRCUIT (Optional)

Green color-coded receptacle (only available with external power) connects to:

- Power Circuit Cable(s)

POWER CIRCUIT (12/24 VDC, External Power)

Green color-coded receptacle connects to:

- Power Circuit Cable(s)

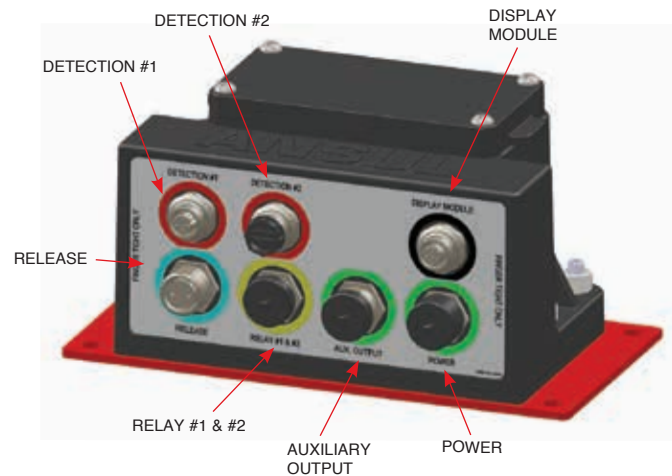

FIGURE 1-2
CHECKFIRE 210 ICM RECEPTACLES
009273

CHECKFIRE 210 System Connectivity (Continued)

TYPICAL SYSTEM CONNECTIONS

The Display Module continually exhibits system status. Color-coded receptacles on the Interface Control Module (ICM) provide ease of CHECKFIRE 210 System installation. See Figure 1-3.

Display Module Circuit: Permits connection between the Display Module and the ICM.

Detection Circuit (#1 and #2): Permits multiple-detection options using Detection Circuit Cable and Tees.

- Electric Manual Actuators (EMA)
- Linear Detectors
- Spot Thermal Detectors
- Pressure Switch (if Detection Circuit #2 is programmed for pressure switch feedback)

Release Circuit: Connects up to a maximum of 10 Electric-Pneumatic Actuators installed on agent tank expellant gas cartridges using Release Circuit Cable(s), Release Circuit Tee(s) (needed for additional tanks), and Release Circuit Drop Cable(s).

Power Circuit: Provides a direct connection to the external power source using Power Circuit Cable(s) and a single Fused Power Circuit Cable.

Auxiliary Output Circuit: Provides auxiliary power output to additional notification devices (horns, strobes, etc.) when ICM is using external power (connection by others).

Relay #1 and #2 Circuit: Provides connection for two internal Relays with SPDT Form “C” 6A @ 30 VDC Automotive contacts; (connection by others).

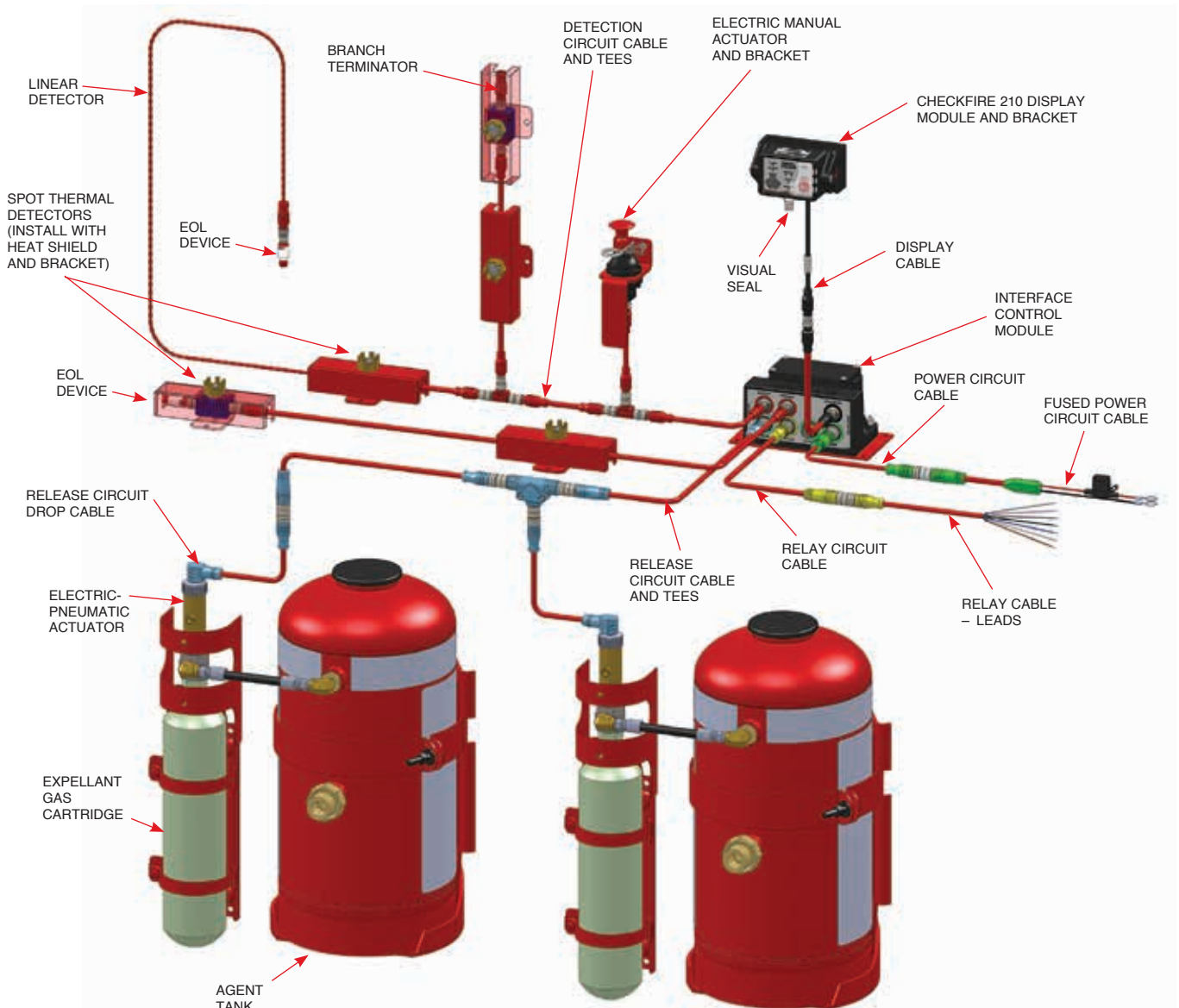

FIGURE 1-3
SYSTEM CONNECTIONS

NOTES:

CHECKFIRE 210 DISPLAY MODULE
Part No. 439560

Provides communication with the Interface Control Module (ICM) and indicates system status See Figure 2-1.

- Dust and water tight (IP67 rated)
- Durable high-strength glass-filled nylon material
- UL94 Flame rating
- Surface or bracket mounted
- Two index pins on back for secure mounting
- Ambient temperature range: – 40 °F to 185 °F (– 40 °C to 85 °C)
- LED indicators provide notification of system status (Internal sounder matches LED pulse rate)
- Internal 85 dB sounder
- “PUSH To Activate / Alarm When Lit” manual-activation button and LED
 - o Provides manual operation (immediate release)
 - o Indicates alarm condition
- Guard door with visual seal to protect manual-activation button
- “DELAY/Reset/Silence” button
 - o Restarts Time Delay #1 (TD1) period before TD1 expires
 - o Resets CHECKFIRE 210 System (during non-alarm status)
 - o Silences internal sounder during fault conditions

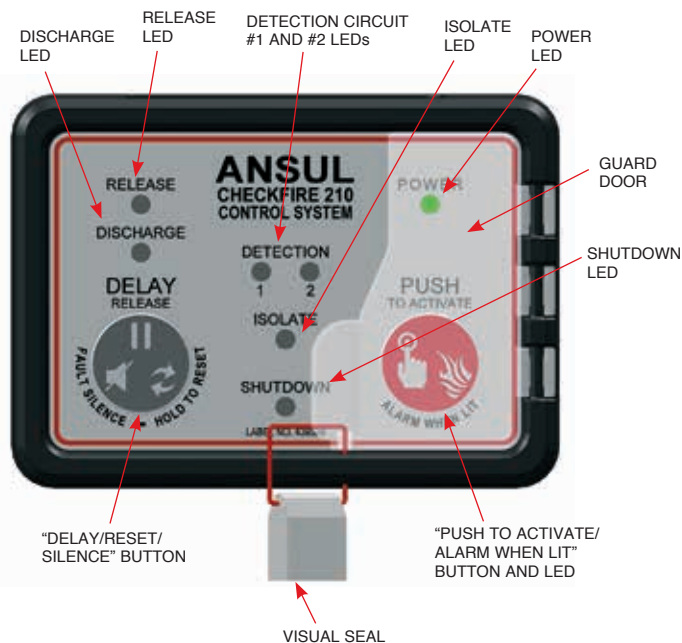

FIGURE 2-1
CHECKFIRE 210 DISPLAY MODULE

009275

CHECKFIRE 110/210 MOUNTING BRACKET
Part No. 439564

Provides flexible bracket mounting of Display Module at various viewing angles. See Figure 2-2.

- Constructed with same high-strength glass-filled nylon material as the Display Module
- Multi-position bracket for securing module in a variety of configurations; use 1/4 in. fasteners of appropriate length with lock washers to secure bracket base to mounting surface
- Dimensions for bracket base, see Figure 2-3

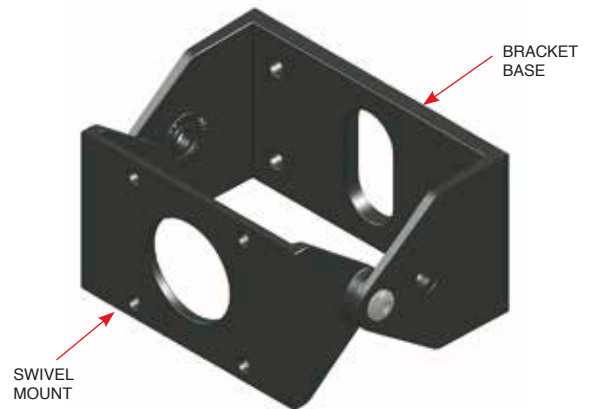

FIGURE 2-2
MOUNTING BRACKET

009152

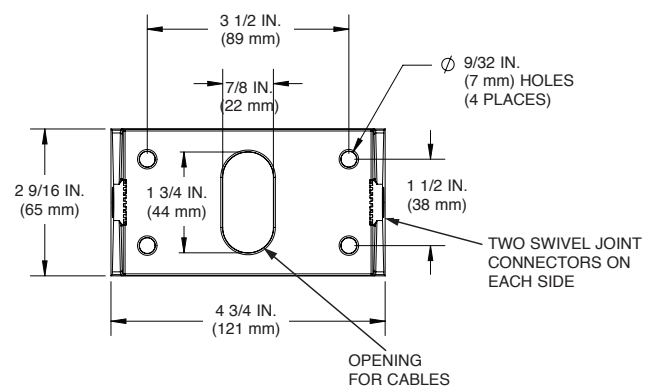

FIGURE 2-3
BRACKET BASE FRONT VIEW

009113

I/O BUS, CANbus, and DISPLAY CABLE

Part No. See table

Connects CHECKFIRE 210 Interface Control Module with Display Module for input/output communications. See Figure 2-4.

- IP67 connectors
- Black color-coded, anti-vibration connectors
- Temperature rating: 302 °F (150 °C)
- Integral connectors on each end of cable
- Multiple lengths for versatility
- Minimum bend radius: 2 1/2 in. (64 mm)
- Maximum circuit length 50 ft (15.24 m)

Display Cable Part Number	Length	
	ft	(m)
439452	2	(0.61)
439454	5	(1.53)
439456	10	(3.05)
439458	20	(6.10)
439460	30	(9.15)
439462	50	(15.24)



**FIGURE 2-4
I/O BUS, CANBUS, AND DISPLAY CABLE**
009276

I/O BUS, CANbus, and DISPLAY CABLE BULKHEAD CONNECTOR

Part No. 439449

Provides feedthrough protection and support for display module communication cable. See Figure 2-5.

- IP67 connectors
- Nickel plated brass construction
- Dimensions: see chart in Appendix
- Plastic isolators for each side of hole



**FIGURE 2-5
I/O BUS, CANBUS, AND DISPLAY CABLE
BULKHEAD CONNECTOR**
009159

ELECTRIC MANUAL ACTUATOR (EMA)
Part No. 439400

Provides electrical activation of the fire suppression system; typically accessible from ground level and/or in a path of egress. See Figure 2-9.

- Electronic signal sent to Interface Control Module immediately activates fire suppression system
- Temperature range: – 40 °F to 185 °F (– 40 °C to 85 °C)



FIGURE 2-9
ELECTRIC MANUAL ACTUATOR (EMA)
009153

OPTIONAL PNEUMATIC MANUAL ACTUATOR
Part No. See system manuals

Provides pneumatic actuation of the fire suppression system from a remote location typically accessible from ground level and/or in a path of egress.

Note: If plans include an optional pneumatic manual actuator in the operator's compartment, refer to detailed components, planning, design and installation guidelines, in the appropriate fire suppression system manual (latest edition).

System Manuals:

LT-A-101-10/20/30 Manual	(Part No. 24327)
LT-A-101-50/125/250 Manual	(Part No. 427865)
LVS Manual	(Part No. 427109)

ELECTRIC MANUAL ACTUATOR BRACKET
Part No. 440537

Constructed of 3/16 in. (4.8 mm) painted steel. Weld or bolt with appropriate fasteners. See Figure 2-10.



FIGURE 2-10
ELECTRIC MANUAL ACTUATOR BRACKET
009154

► **SPOT THERMAL DETECTOR**

Part No. See Temperature Selections Table

Provides spot thermal detection in the protected area(s). See Figure 2-11.

- Color-coded fixed-temperature design
- Temperature rating stamped on detector
- Includes retaining nut to secure detector in bracket and heat shield

Temperature Selections

Rated Operating Temperature °F (°C)	Maximum Continuous Temperature °F (°C)	Color	Spot Thermal Detector
			Part No.
250 (121)	210 (99)	Blue	438280
350 (177)	256 (125)	Red	438281

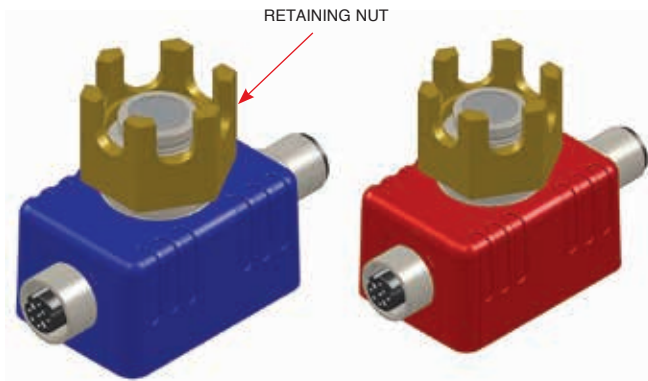

FIGURE 2-11
SPOT THERMAL DETECTORS
009280

► **SPOT THERMAL DETECTOR BRACKET AND HEAT SHIELD**

Part No. 440905

Supports and protects Spot Thermal Detector. See Figure 2-12.

- Detector bracket provides secure mounting
- Retrofittable to existing style detector bracket (Part No. 416221)
- Heat shield provides additional protection for detector body and detection circuit connectors.

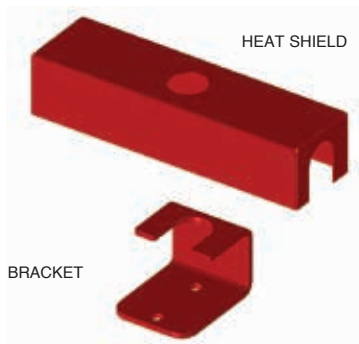

FIGURE 2-12
DETECTOR BRACKET AND HEAT SHIELD
009156

► **LINEAR DETECTOR**

Part No. See table

Provides fire detection in the protected area; connects to the CHECKFIRE 210 Interface Control Module via the Detection Circuit Cable. See Figure 2-13.

Maximum total length of Linear Detector plus Detection Circuit Cable is 750 ft (228.6 m). For example: If Detection Circuit Cable is 50 ft (15.24 m), then Linear Detector could be up to 700 ft (213.4 m).

- Red color-coded connectors
- Two twisted spring steel conductors separated by a heat-sensitive insulator
- Activation temperature rating of 356 °F (180 °C)
- Minimum bend radius, 2 1/2 in. (64 mm)
- Maximum installed continuous operating temperature: 250 °F (121 °C)

Linear Detector Part Number	Length	
	ft	(m)
439406	2	(0.61)
439478	5	(1.53)
439480	10	(3.05)
439408	20	(6.10)
439410	30	(9.15)
440765	50	(15.24)



FIGURE 2-13
LINEAR DETECTOR
009157

DETECTION CIRCUIT CABLE

Part No. See table

Connects to CHECKFIRE 210 Interface Control Module, Electric Manual Actuator(s) (EMA), and detection input components. See Figure 2-14.

Maximum total length of Detection Circuit Cable plus Linear Detector is 750 ft (228.6 m). For example: If Detection Circuit Cable is 50 ft (15.24 m), then Linear Detector could be up to 700 ft (213.4 m).

- IP67 connectors
- Red color-coded, anti-vibration connectors
- Temperature rating: 302 °F (150 °C)
- Integral connectors on each end of cable
- Multiple lengths for versatility
- Minimum bend radius: 2 1/2 in. (64 mm)

Detection Circuit Cable Part Number	Length	
	ft	(m)
439384	2	(0.61)
439386	5	(1.53)
439388	10	(3.05)
439390	20	(6.10)
440759	30	(9.15)
440762	50	(15.24)



FIGURE 2-14
DETECTION CIRCUIT CABLE
009158

DETECTION CIRCUIT BULKHEAD CONNECTOR

Part No. 439404

Provides feedthrough protection and support for detection circuit cable. See Figure 2-15.

- IP67 connectors
- Nickel plated brass construction
- Dimensions: see chart in Appendix
- Plastic isolators for each side of hole



FIGURE 2-15
DETECTION CIRCUIT BULKHEAD CONNECTOR
009159

DETECTION CIRCUIT TEE

Part No. 439394

Connects individual Electric Manual Actuator(s) or Spot Thermal Detector(s) on a branch line to main detection circuit trunk. See Figure 2-16.

- Red color-coded connectors
- Connector temperature rating: 221 °F (105 °C)



FIGURE 2-16
DETECTION CIRCUIT TEE
009160

DETECTION CIRCUIT EOL (End-of-Line) DEVICE

Part No. 439396

Provides circuit supervision and termination point for main detection circuit trunk. See Figure 2-17.

- Red color-coded connector
- Connector temperature rating: 221 °F (105 °C)



FIGURE 2-17
DETECTION CIRCUIT EOL
009161

DETECTION CIRCUIT BRANCH TERMINATOR

Part No. 439398

Identifies branch termination point in the branch detection circuit line. See Figure 2-18.



FIGURE 2-18
DETECTION BRANCH TERMINATOR
009162

RELEASE CIRCUIT CABLE

Part No. See table

Connects to CHECKFIRE 210 Interface Control Module, Release Circuit Tee(s), and/or Release Circuit Drop Cable(s). See Figure 2-19.

- IP67 connectors
- Blue color-coded, anti-vibration connectors
- Temperature rating: 302 °F (150 °C)
- Multiple lengths for versatility
- Maximum circuit length: 250 ft (76.4 m)
- Minimum bend radius: 2 1/2 in. (64 mm)

Release Circuit Cable Part Number	Length	
	ft	(m)
439418	2	(0.61)
439420	5	(1.53)
439422	10	(3.05)
439424	20	(6.10)
439426	30	(9.15)
439428	50	(15.24)



**FIGURE 2-19
RELEASE CIRCUIT CABLE**
009163

RELEASE CIRCUIT TEE

Part No. 439434

Connects to Release Circuit Cable and Release Circuit Drop Cable. See Figure 2-20.

- Blue color-coded connectors
- Connector temperature rating: 221 °F (105 °C)

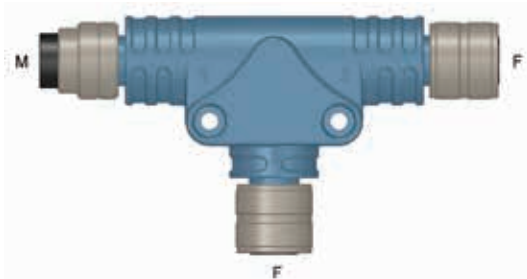

**FIGURE 2-20
RELEASE CIRCUIT TEE**
009164

RELEASE CIRCUIT DROP CABLE

Part No. See table

Provides connectivity between Release Circuit Cable and Electric-Pneumatic Actuator. See Figure 2-21.

- IP67 connectors
- Blue color-coded, anti-vibration connectors
- Temperature rating: 302 °F (150 °C)
- Two lengths for versatility
- Minimum bend radius: 2 1/2 in. (64 mm)

Release Circuit Drop Cable Part Number	Length	
	ft	(m)
439430	30	(0.76)
439432	38	(0.97)



**FIGURE 2-21
RELEASE CIRCUIT DROP CABLE**
009165

RELEASE AND POWER CIRCUITS BULKHEAD CONNECTOR

Part No. 439405

Provides feedthrough protection and support for either release or power circuit cable. See Figure 2-22.

- IP67 connectors
- Nickel plated brass construction
- Dimensions: see chart in Appendix



**FIGURE 2-22
RELEASE CIRCUIT BULKHEAD CONNECTOR**
009166

RELEASE CIRCUIT TERMINATOR

Part No. 439436

Identifies termination point in the release circuit. See Figure 2-23.



**FIGURE 2-23
RELEASE CIRCUIT TERMINATOR**
009167

ELECTRIC-PNEUMATIC ACTUATOR

Part No. 439569 (normally supplied with agent tanks or expellant gas cartridge/bracket assemblies)

Attaches to agent tank expellant gas cartridge and provides release of gas into agent tank. See Figure 2-24.

For electrical activation install Release Circuit Cable Assemblies (with PAD), see Figure 2-27. On system activation, Electric-Pneumatic Actuator punctures a seal in the expellant gas cartridge allowing expellant gas to flow into the agent tank.

The actuator includes a preventor to reduce the possibility of installing actuator with the puncture pin not completely retracted. Note: Do not bend or remove the preventor; it is required for correct operation of the actuator.

The actuator includes optional pneumatic actuation hose ports.

Temperature range:

- Electrically with PAD – 40 °F to 185 °F
 (– 40 °C to 85 °C)
- Pneumatic only – 65 °F to 221 °F
 (– 54 °C to 105 °C)

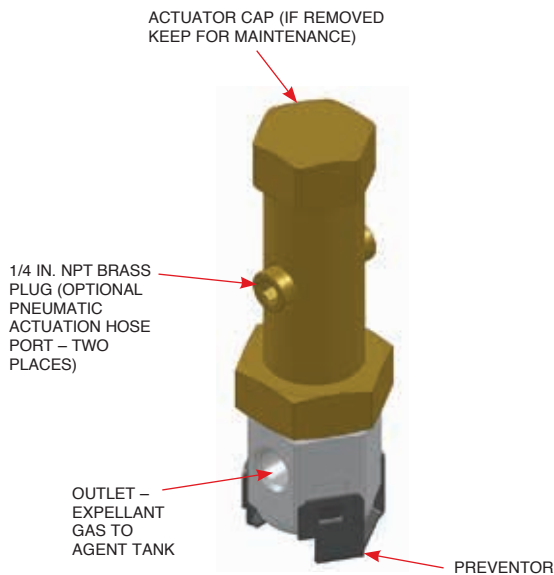

FIGURE 2-24
ELECTRIC-PNEUMATIC ACTUATOR
 009168

PROTRACTING ACTUATION DEVICE (PAD)

Part No. 439448

Provides electrical activation of the fire suppression system. See Figure 2-25 and 2-26.

⚠ CAUTION

When handling the PAD, always point actuating end away from yourself and others. On electrical initiation, PAD operates very quickly and a small brass disk forcefully separates from actuating end. Physical injury may occur from contact with the actuating pin and/or the detaching disk.

- Generates force to drive the Electric-Pneumatic Actuator puncture pin through an expellant gas cartridge seal, allowing the expellant gas to flow into agent tank.
- Integral spade connectors easily field install into the Release Circuit Drop Cable. See Figure 2-25.

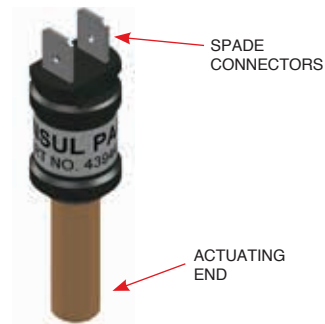

FIGURE 2-25
PAD
 009169



FIGURE 2-26
PAD FIELD INSTALLED IN RELEASE CIRCUIT DROP CABLE
 009170

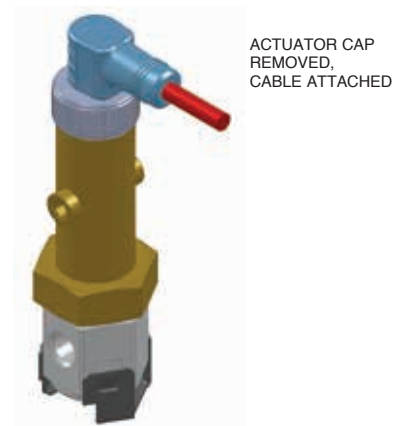

FIGURE 2-27
ELECTRICAL ACTUATION FOR ELECTRIC-PNEUMATIC ACTUATOR
 009171

**BACKUP POWER/RELAY CIRCUIT CABLE
(RELAY #1 and #2) (Yellow Connectors)**

Part No. See table

Connects CHECKFIRE 210 Interface Control Module with relay circuits provided by others. See Figure 2-28 and 2-29.

- IP67 connectors
- Yellow color-coded, anti-vibration connectors
- Temperature rating: 302 °F (150 °C)
- Contact Rating for both relays: 30 VDC at 6 amps
- Integral connectors on each end of cable
- Multiple lengths for versatility
- Minimum bend radius: 2 1/2 in. (64 mm)

Relay Circuit Cable Part Number	Length	
	ft	(m)
439466*	3	(0.91)
440410	2	(0.61)
440413	5	(1.53)
439482	10	(3.05)
440416	20	(6.10)

* Relay Circuit Cable with Leads



**FIGURE 2-28
RELAY CIRCUIT CABLE**
009282



**FIGURE 2-29
RELAY CIRCUIT CABLE - LEADS**
009283

**BACKUP POWER/RELAY CIRCUIT BULKHEAD
CONNECTOR**

Part No. 441303

Provides feedthrough protection and support for either backup power or relay circuit. See Figure 2-30.

- IP67 connectors
- Nickel plated brass construction
- Dimensions: see chart in Appendix



**FIGURE 2-30
BACKUP POWER/RELAY CIRCUIT
BULKHEAD CONNECTOR**
009166

AUXILIARY POWER CABLE (Green Connectors)

Part No. See table

Connects CHECKFIRE 210 Interface Control Module with auxiliary circuits provided by others. See Figures 2-31 and 2-32.

- IP67 connectors
- Green color-coded, anti-vibration connectors
- Temperature rating: 302 °F (150 °C)
- Multiple lengths for versatility
- Maximum circuit current rating: 1.5A
- Minimum bend radius: 2 1/2 in. (64 mm)

Power Circuit Cable Part Number	Length	
	ft	(m)
439450*	3	(0.91)
439438	2	(0.61)
439440	5	(1.53)
439442	10	(3.05)
439444	20	(6.10)
439446	30	(9.15)
440187	50	(15.24)

* Auxiliary Output Power Cable with Leads



**FIGURE 2-31
POWER CIRCUIT CABLES**
009172



**FIGURE 2-32
AUXILIARY OUTPUT POWER CABLE WITH LEADS**
009284

POWER CIRCUIT CABLE

Part No. See table

Connects CHECKFIRE 210 Interface Control Module to Fused Power Circuit Cable. See Figure 2-33.

- IP67 connectors
- Green color-coded, anti-vibration connectors
- Temperature rating: 302 °F (150 °C)
- Multiple lengths for versatility
- Maximum circuit length: 50 ft. (15.24 m): Excludes 3 ft (10.9 m) fused Power Circuit Cable
- Minimum bend radius: 2 1/2 in. (64 mm)

Power Circuit Cable Part Number	Length	
	ft	(m)
439438	2	(0.61)
439440	5	(1.53)
439442	10	(3.05)
439444	20	(6.10)
439446	30	(9.15)
440187	50	(15.24)



**FIGURE 2-33
POWER CIRCUIT CABLE**
009172

RELEASE AND POWER CIRCUITS BULKHEAD CONNECTOR

Part No. 439405

Provides feedthrough protection and support for either release or power circuit cable. See Figure 2-35.

- IP67 connectors
- Nickel plated brass construction
- Dimensions: see chart in Appendix



**FIGURE 2-35
POWER CIRCUIT BULKHEAD CONNECTOR**
009166

FUSED POWER CIRCUIT CABLE

Part No. 439492

Connects Power Circuit Cable to the 12/24 VDC external power source. See Figure 2-34.

- IP67 connector
- Green color-coded, anti-vibration connector
- Minimum bend radius: 2 1/2 in. (64 mm)
- 3 amp inline ATO/ATC blade style automotive fuse
- 1/2 in. ring terminals for power source connection

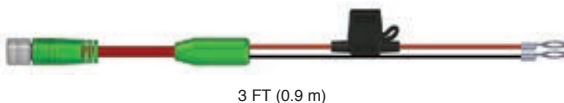

**FIGURE 2-34
FUSED POWER CIRCUIT CABLE**

LABEL PACKAGE
Part No. 440798

Provides instructions for vehicle/equipment operators and service personnel on system operation and protection.

Attach appropriate labels as needed in the specified locations. See Figures 2-36 thru 2-39.

If automatic vehicle/equipment shutdown is part of the CHECKFIRE System, install Label No. 440799 near the operator's line of vision. Cut out the correct time delay value from Label No. 440800, remove backing to expose adhesive, and attach to Label 440799 in the space provided. See Figure 2-36.



FIGURE 2-36
LABEL FOR ENGINE SHUTDOWN AND TIME DELAY
 009174

If automatic vehicle/equipment shutdown is **NOT** part of the CHECKFIRE System, install Label No. 440801 near the operator's line of vision. See Figure 2-37.

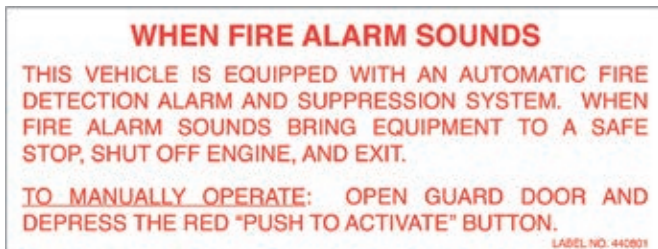

FIGURE 2-37
LABEL TO STOP EQUIPMENT AND EXIT
 009175

As a reminder to service and maintenance personnel, install this CAUTION (Label No. 71455) in the area protected by the Linear Detector. See Figure 2-38.

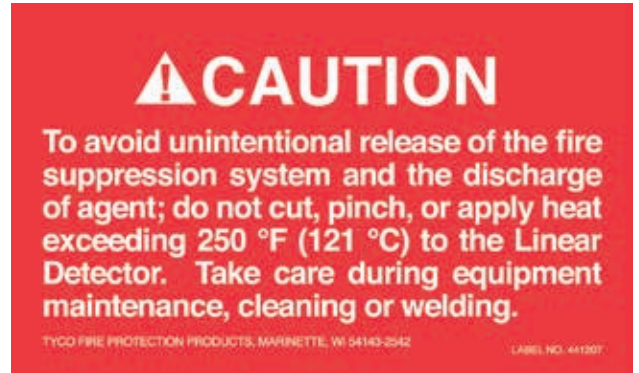

FIGURE 2-38
LABEL FOR PROTECTING LINEAR DETECTOR
 009325

Install this label next to every Electric Manual Actuator (EMA). See Figure 2-39.



FIGURE 2-39
INSTRUCTION LABEL FOR EMA
 009324

DISCHARGE PRESSURE SWITCH ASSEMBLY

Part No. 440389

Provides pressure switch feedback to the ICM through Detection Circuit #2. See Figure 2-40.

- One integral cable, sealed to switch housing
- Manually resettable SPDT switch
- Rated for 6A with 12/36 VDC nominal
- Temperature range: – 40 °F to 175 °F
(– 40 °C to 79 °C)
- Includes 1/4 in. brass tee and nipple

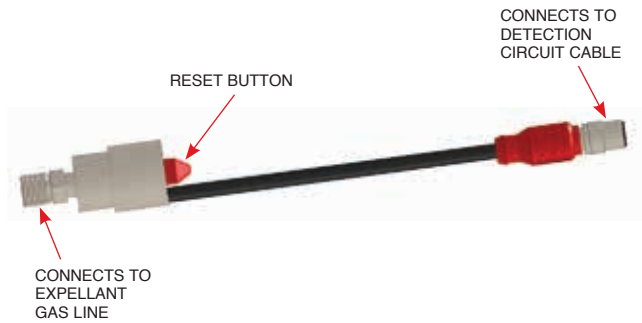

FIGURE 2-40
DISCHARGE PRESSURE SWITCH CONNECTIONS

009344

Install switch in expellant gas line next to agent tank inlet port. Make certain to protect switch and connections from potential damage. See Figure 2-41.

CAUTION

Locate pressure switch next to agent tank at end of expellant gas line. Failure to comply will cause pressure switch to not function properly.

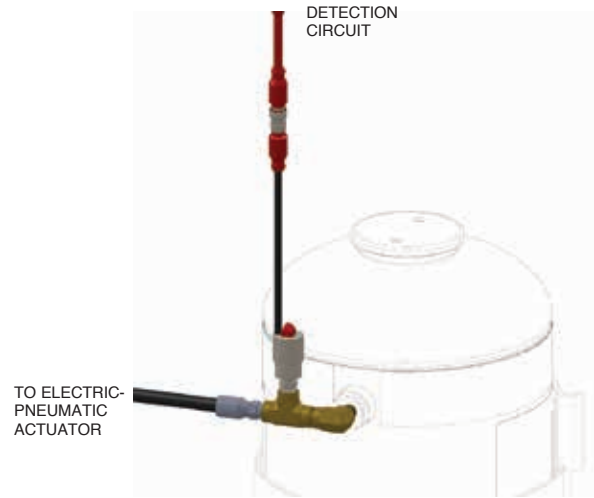

FIGURE 2-41
DISCHARGE PRESSURE SWITCH INSTALLATION

Insert: FIG 2-33.PSD

Note: Pressure switch activates on expellant gas release.

DETECTION CIRCUIT TESTER
Part No. 440097

Simulates normal, fault, and alarm conditions for testing the CHECKFIRE 210 System performance. See Figure 2-42.

Switch settings:

Normal

Fault

Alarm

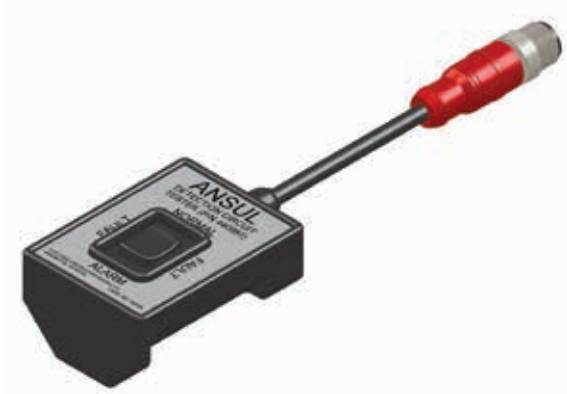

FIGURE 2-42
DETECTION CIRCUIT TESTER
009287

RELEASE CIRCUIT TESTER
Part No. 441021

Indicates a successful release energy pulse to fire the PAD (pass or fail). See Figure 2-43.



FIGURE 2-43
RELEASE CIRCUIT TESTER
009288

RELEASE CIRCUIT TEST PLUG
Part No. 440912

Replaces a PAD for testing the CHECKFIRE 210 System. See Figure 2-44.



FIGURE 2-44
RELEASE CIRCUIT TEST PLUG
009289

SECTION 2 – COMPONENTS

PAGE 2-14 REV. 0 2014-MAY-02

*CHECKFIRE 210
Detection and Actuation System*

NOTES:

USER INTERFACE

This section provides the user with overall information on features and operation of the CHECKFIRE 210 Display Module and Interface Control Module (ICM).

FIELD CONNECTIVITY – Cables and Devices

The CHECKFIRE 210 ICM communicates with the Display Module and other devices through cable assemblies incorporating IP67 circular threaded connectors with color-coded overmolding.

IP67 is an environmental ingress protection rating. The first number indicates protection from solid objects (0 is no special protection, 6 is protection from dust). The second number is protection against liquids (0 is no protection, 7 is protection against the effect of immersion in water).

Display Cable (See Figure 3-2)

- 24 in. (610 mm) Cable
- Black color-coded IP67 anti-vibration connector (Female)



FIGURE 3-1
DISPLAY CABLE
009272

DISPLAY MODULE FRONT PANEL BUTTONS

“DELAY/Reset/Silence” Button

Manage fault and/or alarm conditions by pressing the “DELAY/Reset/Silence” button (see Figure 3-2) for the following results:

- **Audible Fault Silence**
 - o Silence an audible notification during a fault condition for two hours. Fault LED indicator(s) continue pulsing until the fault condition has been cleared.
 - o During a post-release condition the button will silence the sounder.
 - o Any new alarm or fault conditions will reactivate the audible notification.
 - o The audible notification for either a post-release or fault condition will resume after being silenced for two hours.
- **Restart Time Delay Sequence**

Restart the time delay cycle during an alarm condition; must be initiated before Time Delay #1 (TD1) period expires.
- **System Reset**

Press and hold (3 seconds) to reset the system.

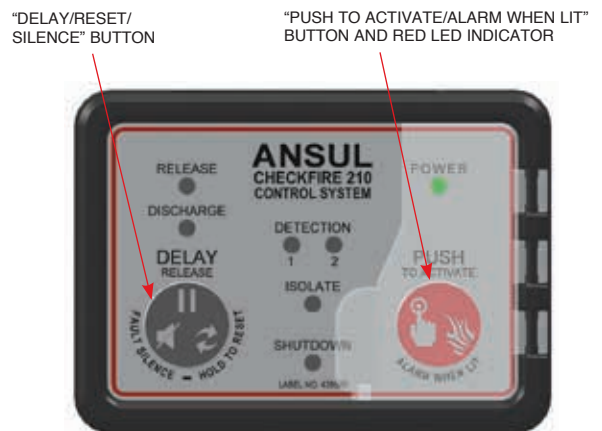

FIGURE 3-2
DISPLAY MODULE FRONT PANEL BUTTONS
009290

DISPLAY MODULE FRONT PANEL BUTTONS (Continued)

Red “PUSH To Activate / Alarm When Lit” Button and LED Indicator (See Figure 3-2)

- Combination button and LED indicator
- **MANUAL ACTIVATION** - Pressing the red “PUSH To Activate / Alarm When Lit” Button immediately activates the release circuit and illuminates the red LED for 10 seconds.

Note: No time delay occurs when red “PUSH To Activate / Alarm When Lit” Button is pressed.

After 10 seconds, the system enters Post Release Activated mode.

- **DETECTOR ACTIVATION** - The “PUSH To Activate / Alarm When Lit” LED indicator displays the conditions listed in Table 3-1.

PRE-ALARM CONDITION (PREVIOUS TO TD1)

LED pulses RED 1 x 1 second during an alarm only or first alarm condition with Cross-Zone programming or alarm condition in Isolate Mode.

ALARM CONDITION:

Time Delay #1 (TD1)

LED pulses RED 2 x 1 second until last 5 seconds of Time Delay #1 (TD1) period (sounder matches pulse rate).

In last 5 seconds of TD1, LED pulses RED 4 x 1 second for 4 seconds; in the final second LED is off (sounder matches shutdown LED pulse rate).

Time Delay #2 (TD2)

LED pulses RED 4 x 1 second until Time Delay #2 (TD2) period expires (sounder matches pulse rate).

Release Activated

LED illuminates RED and remains steady-on for 10 seconds (release circuit active) (sounder remains steady-on).

Post Release Activated

No LED indication (sounder matches other LED indications).

Table 3-1 – ALARM CONDITION LED INDICATORS

		DETECTION CIRCUIT #1 and/or #2 LED(s)	"PUSH To Activate / Alarm When Lit" LED	DISCHARGE LED	SHUTDOWN LED			
Manual Action (Immediate Release Circuit Activation)		1 x 1 sec.	Steady-on for 10 sec.	Steady-on for 10 sec.	Steady-on for 10 sec.			
Push the "PUSH To Activate/Alarm When Lit" button, Release Activated		2 x 1 sec.	1 x 10 sec. until cleared & reset**	1 x 10 sec. until cleared & reset**	1 x 10 sec. until cleared & reset**			
Post Release Activated		4 x 1 sec.	1 x 1 sec.	4 x 1 sec.	1 x 10 sec. until cleared & reset**			
Pull ring pin and strike button on EMA*** Release Activated			1 x 10 sec. until cleared & reset**					
Post Release Activated								
Automatic Action (Detector Activation) (Detection Circuit #1 and/or #2 Input - Alarm Condition)								
Alarm Only Programming or Isolate Mode								
Time Delay #1 (TD1) Programmed for:	0 seconds	Immediately Enters Time Delay 2						
	10 or 15 seconds							
	5, 10 or 15 seconds (Starting the last five seconds of TD1)							
	5, 10 or 15 seconds (Last second of TD1)							
Time Delay #2 (TD2) Programmed for:	0 seconds	Immediately Activates Release Circuit When TD1 expires						
	5, 10 or 15 seconds							
	Release Activated (TD2 Expired - Release Circuit Activation)							
Post Release Activated								
Cross-Zone Programming	One Detection Circuit in Alarm (Pre-Alarm Condition)							
	Both Detection Circuits in Alarm	Time Delay #1 (TD1) Programmed for:	0 seconds	Immediately Enters Time Delay 2				
			10 or 15 seconds					
			5, 10 or 15 seconds (Starting the last five seconds of TD1)					
			5, 10 or 15 seconds (Last second of TD1)					
	Time Delay #2 (TD2) Programmed for:	0 seconds	Immediately Activates Release Circuit When TD1 Expires					
		5, 10 or 15 seconds						
		Release Activated (TD2 Expired - Release Circuit Activation)						
Post Release Activated								
Detection Circuit #2 Only	Pressure Switch Feedback Programming****							
	Post Release Activated							

* Sounder pulses at same rate as LED.
 ** Release LED also pulses Amber at this rate.
 *** Detection Circuit 1 or 2 LED indicates; matching the circuit where EMA is installed.
 **** Release Circuit activates, if programmed.

DISPLAY MODULE FRONT PANEL INDICATORS

Power LED (See Figure 3-3)

- Internal Power status – Power LED pulses GREEN 1 x 3 seconds during normal operation
- External Power/Dual Power status - Power LED illuminates GREEN and remains steady-on during normal operation
- Power Fault Conditions
 - o Independent Internal Power Fault status - Amber Power LED and sounder pulse 1 x 10 seconds indicating power from the internal power source dropped below acceptable level causing a fault condition.
 - o Independent External Power Fault status – Amber Power LED and sounder pulse 1 x 10 seconds indicating power from the external power source dropped below acceptable level causing a fault condition.
 - o Internal/External Dual Power Fault status - Amber Power LED pulses 1 x 3 seconds indicating power from the external power source dropped below acceptable level causing a fault condition and system is operating on internal power supply (sounder does not operate to conserve power).
 - o Internal Battery Life Fault - Amber Power LED and sounder pulse 1 x 10 seconds indicating power from the internal power source dropped below acceptable level causing a fault condition.
 - o Fault conditions will continue pulsing AMBER as long as fault exists or until system powers down.

Release Circuit LED (See Figure 3-3)

- Pulsed AMBER 1 x 10 seconds (sounder matches pulse rate) during a fault condition
- Returns to normal (no indication) when fault is cleared

Discharge LED (See Figure 3-3)

This LED is only active when Pressure Switch Feedback is programmed.

- Illuminates RED steady-on when pressure switch activates for the remainder of Release Activated period (see Table 3-1)
- Pulsed RED 1 x 10 seconds in post release activated (see Table 3-1)
- Controlled by an external pressure switch and provides indication of rising pressure in the expellant gas line

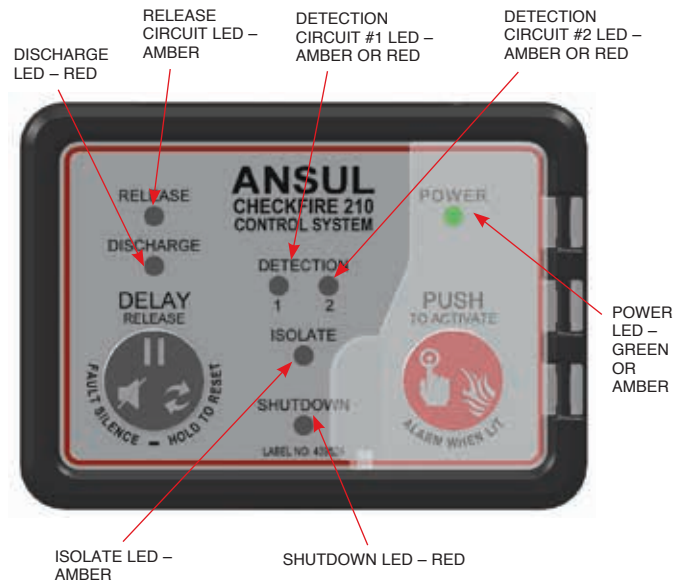

FIGURE 3-3
DISPLAY MODULE FRONT PANEL
 009290

Detection Circuit #1 LED (See Figure 3-3)

- Pulsed RED in an alarm condition (see Table 3-1)
- Pulsed AMBER 1 x 10 seconds (sounder matches pulse rate) during a fault condition
- Returns to normal (no indication) when fault or alarm condition is cleared

Detection Circuit #2 LED (See Figure 3-3)

- Pulsed RED in an alarm condition (see Table 3-1)
- Pulsed AMBER 1 x 10 seconds (sounder matches pulse rate) during a fault condition
- Returns to normal (no indication) when fault or alarm condition is cleared

Isolate LED (See Figure 3-3)

- Pulsed AMBER 2 x 30 seconds to indicate the system is in Isolate Mode
- Use Isolate Mode when performing maintenance on the vehicle/equipment to inhibit automatic release of the fire suppression system

DISPLAY MODULE FRONT PANEL INDICATORS (Continued)

Shutdown LED (See Figure 3-3)

- Pulses RED 4 x 1 second in an alarm condition beginning in the last 5 seconds of TD1 (see Table 3-1)
- Illuminates RED steady-on in the last second of TD1 (see Table 3-1)
- Pulses RED 4 x 1 second during TD2
- Indicates Release Activated and Post Release Activated conditions (see Table 3-1)

INTERNAL SOUNDER (AUDIBLE NOTIFICATION)

- Audible notification for all alarm and fault conditions, except for external fault in a dual power system.
- Pulses at same rate as a corresponding LED indicator(s) (see Table 3-1), unless silenced
- Minimum 85 dB at 3.3 ft (1 m)

DISPLAY MODULE MOUNTING

Two types of mounting options are available.

- SURFACE MOUNT – Display Module includes integral index pins, foam gasket, rubber washer and securing nut to fasten the display module in place without a bracket. The foam gasket minimizes moisture and dust ingress through the opening.
- BRACKET MOUNT - The optional Mounting Bracket (Part No. 439564) is constructed of durable high-strength glass-filled nylon material. The pivot and secure feature accommodates easy operator visual identification and access to the CHECKFIRE 210 Display Module for status indications and manual operation. See Figure 3-4.

Note: The display module should never be mounted in an area subject to pressure washing or steam cleaning.



FIGURE 3-4
DISPLAY MODULE BRACKET
009181

POWER

Internal Power

The CHECKFIRE 210 System has an internal power source (ICM Battery Module (Part No. 440352)) providing up to 365 days of power under normal operating conditions. The Power LED pulses GREEN 1 x 3 seconds for internal power. The battery module is supervised for low power conditions when operating independently.

External Power

The CHECKFIRE 210 System may use equipment power as the external power source. The Power LED illuminates GREEN steady-on for external power. The external power circuit requires 12/24 VDC nominal and is supervised for low power conditions.

Dual Power

When both external power and internal power are connected, the internal power source serves as the reserve power source.

INTERFACE CONTROL MODULE

The CHECKFIRE 210 Interface Control Module (ICM) includes system electronics, and receptacles for system cables. The battery compartment cover helps protect the internal power supply, mini USB port, and programming interface. See Figure 3-5.

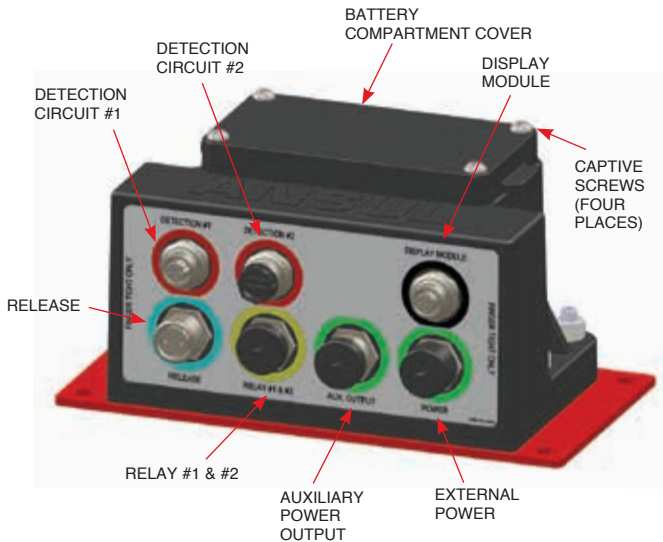

FIGURE 3-5
CHECKFIRE 210 ICM RECEPTACLES
 009273

Detection Circuit #1 Receptacle (Red)

Provides connection point for detection circuit cable and devices.

Detection Circuit #2 Receptacle (Red)

Provides connection point for detection circuit cable, devices or pressure switch.

Display Module Receptacle (Black)

Provides the connection point for the display cable.

Release Circuit Receptacle (Blue)

Provides the connection point for the release circuit cable to electric-pneumatic actuators.

Relay #1 & #2 Receptacle (Yellow)

Provides the connection point for a maximum of two internal relays to control external devices (by others). The Relay Cable with Leads component has 6 lead wires (3 wires for each relay).

Auxiliary Output Receptacle (Green)

Provides the connection point for output power (for horns, strobes, etc.), regulated to the system voltage 12/24 VDC (1.5 amps maximum). This power output is only available when using external (vehicle/equipment) power to operate the CHECKFIRE 210 System.

Power Receptacle (Green)

Provides the connection point for external power.

Battery Compartment Cover

The battery compartment cover is located on the ICM near the embossed ANSUL logo and can be removed by loosening the four captive screws, see Figure 3-5. The cover fits over an o-ring seal on the ICM enclosure and provides an IP67 rated seal when properly installed. See Figure 3-6.

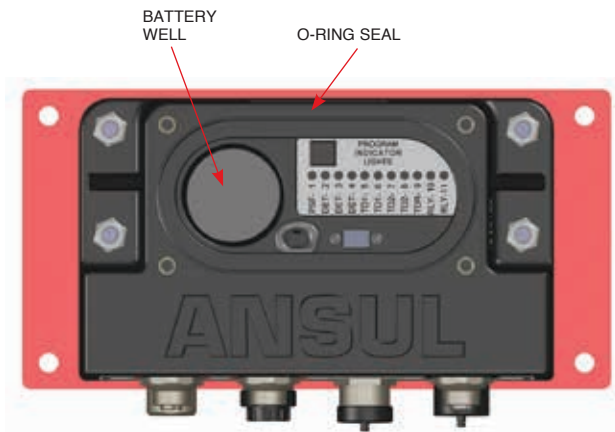

FIGURE 3-6
ICM COVER REMOVED
 009279

INTERFACE CONTROL MODULE (Continued)

ICM Programming Panel

Remove the battery cover for access to the programming button and associated program indicator lights (LEDs). The mini USB port and battery cable for the internal battery module are next to the LEDs. See Figure 3-7.

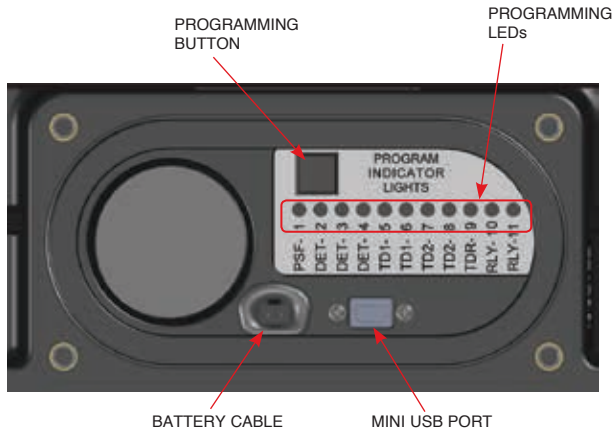

FIGURE 3-7
ICM PROGRAMMING PANEL
009292

System Isolate Switch

The CHECKFIRE 210 System includes an isolation feature for end-users to minimize the occurrence of a false discharge when service or maintenance is being performed on the protected vehicle/equipment (not intended for CHECKFIRE 210 System maintenance).

The System is placed in Isolate Mode by operating the isolate switch located on the side of the ICM enclosure. While in isolate mode, the LED and sounder on the Display Module quickly pulse 2 x 30 seconds. If desired, to silence the sounder push the "DELAY/Reset/Silence" button. See Figure 3-7.

When placed in Isolate Mode, an automatic detection circuit input (alarm condition) will not initiate the release circuit. However, a manual actuation by either an EMA or the "PUSH to Activate/ Alarm When Lit" button bypasses the isolation feature and immediately activates the release circuit.

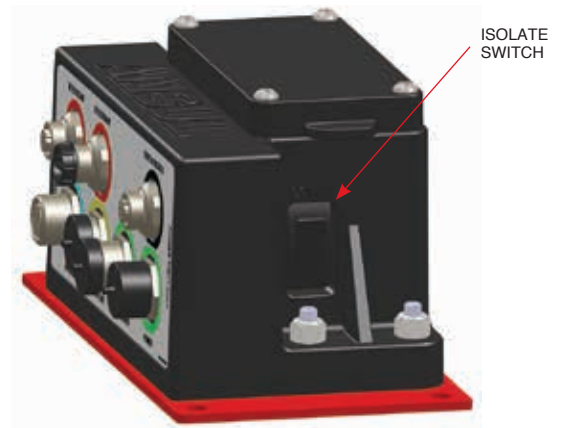

FIGURE 3-7
ICM ISOLATE SWITCH
009277

NOTES:

HAZARD IDENTIFICATION BASIC PLANNING

Individuals responsible for planning (or designing) a CHECKFIRE 210 Detection and Actuation System must hold current ANSUL Certification from an ANSUL A-101 and/or LVS training program. In addition to the certification, planners must research:

- Known fire hazards in equipment to be protected
- Federal and local fire protection codes/standards

For easier planning obtain a general model drawing of the vehicle/equipment with accurate dimensions.

Identify hazard areas needing protection. Agent nozzles in existing fire suppression systems may point out hazard areas. For existing or new fire suppression/detection systems review and apply the following vital information to determine proper placement of discharge nozzles and detection devices.

Fire Hazard Locations

A fire hazard is any area where an ignition source (heat, high temperature or sparks) and fuel (flammable materials) may be found in close proximity. A solid or liquid combustible or flammable material can cause fire when in contact with an ignition (heat) source. Fire hazard areas may also exist in locations where fire can propagate due to dripping or running flammable liquids.

Examples of ignition (heat) sources:

- Engines
- Exhaust manifolds and piping
- Turbochargers
- Power source compartments
- Electrical system equipment
- Torque converters
- Transmissions
- Hydraulic pumps
- Parking brakes (engaged while moving)
- Bearings, clutches or gears
- Malfunctioning components
- Friction from debris packed around parts

Examples of fuel or flammable materials (may cause rapid buildup or spreading of fire):

CLASS B MATERIALS

- Leaking fuel (gasoline, diesel, engine oil, hydraulic oil, glycol, steering fluid, etc.)
- Broken fuel lines/fittings
- Slow leaks – fuel or hydraulic fluid
- Broken hydraulic lines or pumps
- High pressure hoses
- Belly pan (fuel and debris accumulation)
- Ruptured fuel or hydraulic tank
- Greases

CLASS A MATERIALS

- Electric wiring insulation
- Plastic parts
- Rubber
- Debris (wood chips, coal dust, landfill material, etc.)

Identify every foreseeable hazard. Include the occasional danger of malfunctioning components.

Other Considerations

The propagation of fire from one area to another may cause a hazard to be larger than originally determined. Liquid fuel may flow, spray, or splash causing the fire to spread further than anticipated. Radiation, sparks, or conduction through metal can carry heat to an area where the danger of fire would not normally exist. Hand portable fire extinguishers should be accessible to suppress residual fires or to help with providing an escape route.

Research the fire history of the equipment or of similar equipment. This information may be available through company records or equipment operators who may have first-hand experience enabling them to identify locations of previous fires as well as specific hazards such as frequent component wear, fuel leak points, or ruptures of certain hydraulic fittings or hoses.

Normal operating temperatures in excess of the detector ratings will cause the detection system to activate.

Each identified hazard must include both fire suppression system fixed nozzles and linear detectors or spot thermal detectors for automatic detection and system activation.

Equipment Shutdown

Plan for the shutdown of components that could add to the intensity of the fire, re-ignite the fire, or negatively impact the discharge of fire suppression agent such as:

- Fuel pumps
- Hydraulic pumps
- Engine
- Power source
- Electrical system
- Fans

Automatic pressure bleed-down and/or fuel and hydraulic tank shutoff valves should also be considered to mitigate fire propagation and/or re-flash.

Electrical interface for automatic equipment shutdown can be made utilizing either the programmable #2 internal relay in the ICM or the Pressure Switch Assembly (Part No. 440389) alone. When the pressure switch alone is used, shutdown will occur simultaneously with system release. When the pressure switch is used in conjunction with Detection Circuit #2 as pressure switch feedback, and pneumatic actuation is utilized, the programmable #2 internal relay contacts will transfer, and connected equipment will become energized or de-energized depending on how the relay is wired.

Consult the vehicle/equipment manufacturer, the manufacturer's dealer, the site maintenance manager or customer for details when planning for either shutdown method.

Notification – Operator Safety

Fire can occur in locations not visible to the vehicle operator. In addition, noisy vehicle operation may result in difficulty hearing the internal sounder in the CHECKFIRE 210 Display Module. In adverse conditions such as these and others, a high decibel alarm with or without flashing strobe (provided by others) may warn the operator the CHECKFIRE 210 System is in an alarm condition, is in a fault condition or the fire suppression system is discharging.

Options for controlling these external devices include two internal programmable relays on the CHECKFIRE 210 ICM, and the Pressure Switch Assembly (Part No. 440389). The relays can provide indication for system fault, shutdown, and alarm conditions. Options for powering external devices include the auxiliary power output from the ICM or connecting to the vehicle/equipment power.

For safety, plan to evacuate the vehicle/equipment at the earliest possible moment.

The display module pulsing LEDs and 85 dB sounder are intended to alert the operator when the unit receives a fault signal or alarm condition from a detection device (before actuating the fire suppression system).

SPECIFIC PLANNING INFORMATION

Review the following information to plan the CHECKFIRE 210 System layout. Create a drawing of the proposed plan showing locations of components and cable on the vehicle/equipment. This will help avoid unforeseen installation problems. Once an acceptable layout is complete; record and keep it for future reference.

Programming Options

The versatility of the CHECKFIRE 210 System provides multiple options such as detection, user notification, and confirmation of system discharge. Review the following sections and determine proper programming for the system. Track programming selections on the Planning Checklist Template, see page 4-11.

PRESSURE SWITCH FEEDBACK

With the Pressure Switch Feedback option enabled, Detection Circuit #2 becomes the input circuit for System pressure switches. The System monitors the circuit for both open conditions and shorted conditions.

An open condition on the circuit is indicated by a Fault condition on Detection Circuit #2 and could indicate low pressure in an expellant gas cartridge.

A shorted condition on the circuit is indicated by an alarm condition on Detection Circuit #2 and could be initiated by rising pressure in the expellant gas piping. When activated, the display module Discharge LED and sounder notify the operator of the fire suppression system discharge.

A programmable option for the pressure switch feedback is sending a release signal to PAD(s) when the switch activates. This provides redundant activation of all associated PAD(s).

Note: When Pressure Switch Feedback is programmed, the Cross-Zone option is not available.

CROSS-ZONE DETECTION

Selecting Cross-Zone Detection requires both detection circuits (#1 and #2) to have an alarm condition before the start of Time Delay #1 (TD1) and the automatic release process.

If an alarm condition is present on one detection circuit, the System will provide audible and visual alarm indication (pulsing 1 x 1 second). TD1 will not start until an alarm condition occurs in the other detection circuit. Once both detection circuits are in alarm, the System will start TD1 (pulsing 2 x 1 second).

If one of the detection circuits clears during TD1, the system returns to indicating audible and visual alarm indication only (pulsing 1 x 1 second) clearing TD1.

If both detection circuits stay in alarm condition during TD1 the system proceeds through time delays and automatically activates the fire suppression system.

Manual activation of the System is always available to the operator by pushing the “PUSH To Activate / Alarm When Lit” button, or operating an EMA.

Note: When Cross-Zone is programmed, the Pressure Switch Feedback option is not available.

ALARM ONLY

For certain situations requiring manual actuation of the fire suppression system, the CHECKFIRE 210 System can be programmed to provide Alarm Only notification (pulsing 1 x 1 second) of an alarm condition on Detection Circuit #1, Detection Circuit #2, or both together. The Alarm Only programming provides visual and audible indication for the operator of an alarm condition and will not start the automatic release process for the fire suppression system.

If only one circuit is programmed to Alarm Only, the other circuit can function as an independent detection/release circuit.

CAUTION

Programming both Detection Circuit #1 and Detection Circuit #2 for Alarm Only functionality will disable all automatic release functions of the CHECKFIRE 210 System. Manual activation of the fire suppression system is required for release. Failure to manually activate the system can result in significant property damage or personnel injury.

When manual activation is required, perform one of the following to manually operate the system:

- Open guard door on CHECKFIRE 210 Display Module (break visual seal), and push the “PUSH To Activate / Alarm When Lit” button.
- Pull ring pin and strike red button on an Electric Manual Actuator (EMA).
- If an optional pneumatic actuation system is installed, pull ring pin and strike red button on the pneumatic manual actuator.

Programming Options (Continued)

TIME DELAYS AND RESTART PROGRAMMING

Two programmable time delays are available with the CHECKFIRE 210 System. Time Delay #1 (TD1) starts when a detection circuit receives an alarm condition (unless programmed for Alarm Only or Cross-Zone Detection). Time Delay #1 can be restarted by the operator. Time Delay #2 (TD2) starts at the end of TD1, and cannot be restarted.

The Time Delay #1 Restarts option allows the operator to restart TD1 by pushing the “DELAY/Reset/Silence” button. This gives the operator more time, if needed, before fire suppression system release and, if included, equipment shutdown. The Time Delay Restart option is programmable to two restarts or unlimited restarts.

Determine the proper time delay for the hazard, type of equipment, and operating environment. Time delay should be used for safety of operator and others nearby. Time delay duration should be as minimal as needed, because the fire suppression system should be activated as soon as possible.

Time Delay and Restart programming provides the following options:

- Time Delay #1 (TD1) is the initial time delay period and can be programmed for 0, 5, 10 (default) or 15 seconds.
- Time Delay #2 (TD2) is a second time delay period between equipment shutdown (if programmed) and system activation, which can be programmed for 0, 5, 10 (default) or 15 seconds.
- Time Delay Restart of TD1 can be programmed for either 2 restarts (default) or unlimited restarts.

Planning should include a selection for each option.

CAUTION

TD1 is the delay period between an alarm condition and equipment shutdown. If using the shutdown relay function, programming TD1 to zero seconds results in immediate equipment shutdown and immediate start of TD2 upon initiation of an alarm condition

CAUTION

TD2 is the delay period between TD1 and fire suppression release. If using the shutdown relay function, programming TD2 to zero seconds results in immediate fire suppression release at the same time as equipment shutdown.

CAUTION

Programming both Time Delay #1 and Time Delay #2 to zero seconds results in immediate System activation following an alarm condition. This situation could lead to immediate equipment shutdown (if using the shutdown relay function) or other unforeseen issues which could result in significant property damage or personal injury.

CAUTION

Delay of system operation may allow the fire to intensify, which could result in a more difficult fire to suppress.

RELAY CIRCUITS #1 AND #2

The CHECKFIRE 210 System includes two programmable internal, Form C relays (provides normally open (NO) and normally closed (NC) contacts) that can be programmed to transfer on a System alarm, fault or shutdown condition. These relays can control external audible and/or visual signaling devices for either alarm or fault indication. If programmed, relay #2 can be directly connected to equipment shutdown circuitry providing automatic equipment shutdown.

Contact Rating for both relays: 30 VDC nominal at 6 amps.

Relay #1 programming provides the following options:

- Alarm relay (default)
- Fault relay

Relay #2 programming provides the following options:

- Shutdown relay (default)
- Alarm relay

Display Module Location

1. Mount display module in full view, easily accessible, and within reach of the operator. Select a flat surface that will properly support the display module during all vehicle/equipment operating and environmental conditions (e.g., shock and vibration). **Note:** The display module should never be mounted in an area subject to pressure washing or steam cleaning.
2. Confirm the operator has access to the “PUSH To Activate / Alarm When Lit” and the “DELAY/Reset/Silence” buttons.
3. Select a location suitable for surface mounting (3/16 in. (4.7 mm) maximum thickness), or bracket mounting. For bracket mounting, use the optional CHECKFIRE 110/210 Mounting Bracket (Part No. 439564) and secure with screws or bolts. The mounting surface must be flat to avoid strain on the mounting bracket.
4. Confirm access for proper cable connection, periodic inspection, and maintenance. If surface mounted, access to the underside or rear of the mounting surface is necessary. Review the surrounding area to confirm the location will not interfere with normal vehicle/equipment maintenance or operation.

Display Module Location (Continued)

NOTICE

The ambient temperature for the display module location must not fall below -40°F nor exceed 185°F (-40°C to 85°C).

Note: If plans include an optional pneumatic manual actuator in the operator’s compartment, confirm the operator has access to the red strike button on the actuator. For detailed planning/installation guidelines, refer to the appropriate system manual (latest edition):

- LT-A-101-10/20/30 Manual (Part No. 24327)
- LT-A-101-50/125/250 Manual (Part No. 427865)
- LVS Manual (Part No. 427109)

CHECKFIRE 210 Circuit Cable Assemblies

Plan on routing circuit cable assemblies in accessible locations, protected from undue wear, damage, and heat. Cable connectors should not be installed in areas where temperature will exceed 221°F (105°C).

NOTICE

All circuit cables must be supported within 1 ft (305 mm) of each component connection and a maximum of 3 ft (914 mm) between supports with rubber-coated 5/16 in. (8 mm) P-Clamps or double-loop cable ties.

When cables pass through a partition, use a bulkhead connector designed for the appropriate cables. Cables must never be routed through a hole or near sharp edges without being properly protected.

Bulkhead Connectors

<u>Part No.</u>	<u>Maximum Pass-through Thickness</u>	<u>Cable Type</u>
439404	3/8 in. (9.5 mm)	Detection Circuit
439405	1 in. (25 mm)	Release Circuit Power Circuit Aux. Output Circuit
439449	3/8 in. (9.5 m)	Display Cable

Detection Circuit Cable (Red Connectors)

Connects input devices to the CHECKFIRE 210 Interface Control Module (ICM) such as:

- Electric Manual Actuators (EMA)
- Linear Detectors
- Spot Thermal Detectors

1. Determine appropriate detection method (linear detectors or spot thermal detectors) and placement for specific cable end points. **Review specific requirements for each at the end of this section.**
2. Choose a path in accessible locations providing protection from undue wear, damage, and heat. Keep cables as far away as possible from equipment electric cables, particularly power cables to and from generators and electric motors; also avoid:
 - Antennas and associated cables
 - Fire hazard areas
 - Areas exposed to mechanical damage
 - Proximity to moving parts
 - Areas subject to debris accumulation
 - Areas exposed to high temperatures (turbo chargers, exhaust equipment, etc.)
 - Areas requiring access by equipment service and maintenance personnel
3. Plan route for the cable from the ICM to the detection component end points (note end points for cable lengths) using the following rules (see Figure 4-1):
 - Detection Circuit tees can only be installed on the main trunk
 - No double branching
 - No EOL Devices on end of branch line
 - Branch line must end with Detection Circuit Branch Terminator or EMA
 - If used, EMAs must be first component(s) on circuit
 - Each EMA must be on a single use branch line
 - Linear Detector may be used anywhere in the main trunk after the EMA(s) (if installed)
 - Main detection circuit trunk must be terminated with EOL Device

Detection Circuit Cable (Red Connectors) (Continued)

4. Select appropriate cable lengths for area of installation. Total detection circuit length is calculated with the Linear Detector length. Maximum total length of Detection Circuit Main Trunk plus Linear Detector is 750 ft (228.6 m). For example: If Detection Circuit Cable is 50 ft (15.24 m), then Linear Detector could be up to 700 ft (213.4 m). See Section 2 - Components page 2-6, for available sizes. Maximum length for individual branch lines is 250 ft (76 m) (not included with main trunk limit).



FIGURE 4-1
CORRECT DETECTION CIRCUIT INSTALLATION
009293

ELECTRIC MANUAL ACTUATOR (EMA)

If used, connect the EMA to the main detection circuit trunk using a Detection Circuit Tee (Part No. 439394) and appropriate length of Detection Circuit Cable to the EMA. Surface mount (1/4 in. (6.3 mm) maximum thickness) or bracket mount on a flat surface that will properly support the EMA for equipment use and conditions; EMA Bracket (Part No. 440537).

1. When planning the detection circuit layout, the EMA(s), if used, **MUST** be installed before any other device on the detection circuit. See Figure 4-2.
2. Locate EMA where accessible; preferably in path of egress accessible from ground level. If intended for equipment operator manual activation, locate in operator's compartment easily accessible to operator.
3. Each EMA must be branched off the main detection circuit trunk utilizing a detection circuit tee and is the only component allowed on the branch line.



FIGURE 4-2
CORRECT EMA INSTALLATION
009294

LINEAR DETECTOR

Linear Detector (red connectors and twisted cable) connects directly to the main Detection Circuit Cable.

- Only install in main detection circuit trunk
- If used, must be installed after EMA(s)
- Cannot be branched from main detection trunk
- If last device, must include EOL Device (Part No. 439396) for circuit supervision

1. Where possible, install Linear Detector above the hazard area or around the perimeter of a hazard compartment, preferably within normal airflow, for quick response. Do not allow struts, frame members, or other obstacles to act as heat shields between the hazard area and the detection cable. Attach to equipment with rubber-coated 5/16 in. (8 mm) P-Clamps or double-loop cable ties.
2. Do **NOT** install Linear Detector within 12 in. (305 mm) of any area that will become extremely hot during operation, such as:
 - Engine blocks
 - Exhaust manifolds
 - Exhaust tube(s) Mufflers
 - Turbochargers

Note: Maximum installed ambient temperature at the Linear Detector location is 250 °F (121 °C).

3. Make certain to use an adequate length of Linear Detector to effectively detect a fire. To reduce possibility of damage, only use as much Linear Detector as necessary to cover the hazard area(s).
4. The minimum bend radius for Linear Detector must not be less than 2 1/2 in. (64 mm). See Figure 4-3.
5. May be used anywhere in the main detection trunk after EMA(s) (if installed). See Figure 4-3. **Note:** Maximum total length of Linear Detector plus Detection Circuit Main Trunk is 750 ft (228.6 m). For example: If Detection Circuit Cable is 50 ft (15.24 m), then Linear Detector could be up to 700 ft (213.4 m).
6. If last device, install an EOL Device (Part No. 439396) on the end of the Linear Detector. See Figure 4-3.
7. After reviewing the above instructions, select the appropriate length Linear Detector to cover the hazard area(s). See Section 2 - Components, page 2-5, for available sizes.
8. Whenever possible make end point connections outside the hazard area(s).

Detection Circuit Cable (Red Connectors) (Continued)

LINEAR DETECTOR (Continued)

- Keep the detector as far away as possible from equipment electric cables, particularly power cables to and from generators and electric motors.

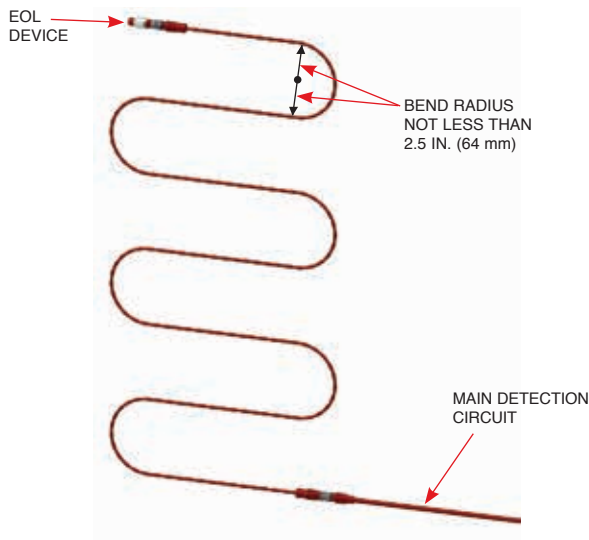

FIGURE 4-3
LINEAR DETECTOR INSTALLATION
 009194

SPOT THERMAL DETECTOR SELECTION AND PLACEMENT

Use spot thermal detectors to meet single-point detection requirements.

Note: When using spot thermal detectors, plan to locate a minimum of two (2) detectors in each hazard area. Large hazard areas will require additional detectors.

- Select according to temperature range relative to hazard temperature (refer to table).

Rated Operating Temperature		Maximum Hazard Temperature		Detector	
°F	(°C)	°F	(°C)	Color	Part No.
250	(121)	210	(99)	Blue	438280
350	(177)	256	(125)	Red	438281

- Mount using provided bracket and heat shield on a flat surface that will properly support the detector during all equipment operating and environmental conditions (e.g., shock and vibration).
- Connect directly to Detection Circuit Cable or connect to Linear Detector assemblies.

- Spot thermal detectors may be run in a branch line from main detection circuit trunk. A branch terminator is required when installed on a branch line. See Figure 4-4.

CAUTION

Do not use an EOL Device at the end of a branch line. The EOL Device will cause incomplete detection circuit supervision and the system will not function properly.

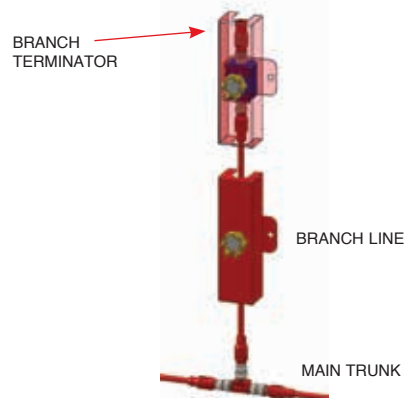

FIGURE 4-4
SPOT THERMAL DETECTOR BRANCH INSTALLATION
 009295

- Install an EOL Device (Part No. 439396) at the end of the main detection circuit trunk. See Figure 4-5.



FIGURE 4-5
SPOT THERMAL DETECTOR MAIN TRUNK INSTALLATION
 009296

Review complete plan layout for the following INCORRECT INSTALLATIONS and adjust as needed.

Detection Circuit Cable (Red Connectors) (Continued)

INCORRECT DESIGN INSTALLATIONS

CAUTION

Do not use an EOL Device on a branch line because the complete detection circuit will not be monitored. (See Figure 4-6 and 4-7). Double branching is not allowed. (See Figures 4-6 thru 4-8). Failure to comply may cause the system to not function properly.

NO EOL DEVICE
ON BRANCH

NO DOUBLE
BRANCHING



FIGURE 4-6
INCORRECT EMA AND EOL INSTALLATION
 009297

EMA MUST BE
ON SINGLE USE
BRANCH

NO EOL DEVICE
ON BRANCH

NO DOUBLE
BRANCHING



FIGURE 4-7
INCORRECT EMA AND EOL INSTALLATION
 009298

CAUTION

Only one EMA may be installed from a detection circuit tee on a single branch line. If multiple EMAs are to be installed, additional branch lines on the main trunk will be required (one EMA per branch line). Incorrect installations will cause the system to not function properly. See Figure 4-8.

EMA MUST BE
ON SINGLE USE
BRANCH

NO DOUBLE
BRANCHING



FIGURE 4-8
INCORRECT EMA INSTALLATION
 009299

CAUTION

Install EMA(s) as the first component(s) on the Detection Circuit and on a single use branch line. Failure to comply may cause the system to not function properly. (See Figure 4-9, and 4-10).

EMA MUST BE
FIRST
COMPONENT AND
ON SINGLE USE
BRANCH



FIGURE 4-9
INCORRECT EMA INSTALLATION
 009300

EMA MUST
BE FIRST



FIGURE 4-10
INCORRECT EMA INSTALLATION
 009301

Detection Circuit Cable (Red Connectors) (Continued)

INCORRECT DESIGN INSTALLATIONS (Continued)

CAUTION

Do not install Linear Detector on a branch line. (See Figure 4-11).



FIGURE 4-11
INCORRECT LINEAR DETECTOR INSTALLATION

009302

Display Cable (Black Connectors)

Connects Display Module to CHECKFIRE 210 ICM.

- Communicates commands, and system status with ICM
 - No tees or branch lines on this circuit
 - Only one display module allowed for each CHECKFIRE 210 System
1. Determine location of display module for specific cable end points.
 2. Plan route for the display cable from the ICM to the display module end point (note end points for cable lengths). Choose a path in accessible locations providing protection from undue wear, damage, and heat. Keep cables as far away as possible from equipment electric cables, particularly power cables to and from generators and electric motors; also avoid:
 - Antennas and associated cables
 - Fire hazard areas
 - Areas exposed to mechanical damage
 - Proximity to moving parts
 - Areas subject to debris accumulation
 - Areas exposed to high temperatures (turbo chargers, exhaust equipment, etc.)
 - Areas requiring access by equipment service and maintenance personnel
 3. Select appropriate cable lengths for area of installation. See Section 2 - Components, page 2-2, for available sizes. Maximum circuit length is 50 ft (15.2 m).

Release Circuit Cable (Blue Connectors)

Connects Electric-Pneumatic Actuator(s) (for agent tank expellant gas cartridges(s)) to CHECKFIRE 210 ICM.

- System activates a maximum of 10 Electric-Pneumatic Actuators (one per tank).
- For electrical activation include a Release Circuit Drop Cable and a Protracting Actuation Device (PAD) (Part No. 439448) for each actuator. Release Circuit Tee (Part No. 439434) required for each additional actuator.
- For optional pneumatic actuation install a pneumatic manual actuator near the operator and/or in path of egress at a point accessible from ground level. Refer to appropriate system manual (latest edition):

System Manuals:

- | | |
|----------------------------|-------------------|
| LT-A-101-10/20/30 Manual | (Part No. 24327) |
| LT-A-101-50/125/250 Manual | (Part No. 427865) |
| LVS Manual | (Part No. 427109) |

1. Determine location of agent tank(s), expellant gas cartridge assembly(s), and actuator(s) for specific cable end points.
2. Plan route for the release circuit cable from the ICM module to the agent tank expellant gas cartridge end point(s) (note end point(s) for cable lengths). Choose a path in accessible locations providing protection from undue wear, damage, and heat. Keep cables as far away as possible from equipment electric cables, particularly power cables to and from generators and electric motors; also avoid:
 - Antennas and associated cables
 - Fire hazard areas
 - Areas exposed to mechanical damage
 - Proximity to moving parts
 - Areas subject to debris accumulation
 - Areas exposed to high temperatures (turbo chargers, exhaust equipment, etc.)
 - Areas requiring access by equipment service and maintenance personnel
3. Select appropriate cable lengths for area of installation. See Section 2 - Components, page 2-9, for available sizes. Maximum 250 ft (76.2 m) allowed.
4. If more than one Electric-Pneumatic Actuator is required, add a Release Circuit Tee and appropriate length Release Circuit Cable for each additional actuator.

Relay Circuit Cable (Yellow Connectors)

Connects external signaling devices and components to CHECKFIRE 210 ICM.

- System controls external devices (supplied by others) using two (2) internal, programmable, Form C relays
 - Relays can be programmed to provide indication for Alarm or Fault (Relay #1), and Shutdown or Alarm (Relay #2).
1. Determine location of connection points for external devices.
 2. Plan route for the relay circuit cable from the ICM to the local termination points (note end points for cable lengths). Choose a path in accessible locations providing protection from undue wear, damage, and heat. Keep cables as far away as possible from equipment electric cables, particularly power cables to and from generators and electric motors; also avoid:
 - Antennas and associated cables
 - Fire hazard areas
 - Areas exposed to mechanical damage
 - Proximity to moving parts
 - Areas subject to debris accumulation
 - Areas exposed to high temperatures (turbo chargers, exhaust equipment, etc.)
 - Areas requiring access by equipment service and maintenance personnel
 3. Select appropriate cable lengths for area of installation. See Section 2 - Components, page 2-7, for available sizes.

Auxiliary Output Circuit Cable (Green Connectors)

Connects external signaling devices and components to CHECKFIRE 210 ICM, and provides a power source when operating the CHECKFIRE 210 on external power.

- External power provides feedthrough of 12/24 VDC @ 1.5 A nominal to auxiliary output circuit
 - Auxiliary Output Voltage is only available if operating the CHECKFIRE 210 System on external power
1. Determine location of connection points for external devices.

2. Plan route for the auxiliary output circuit cable from the ICM to the local termination points (note end points for cable lengths). Choose a path in accessible locations providing protection from undue wear, damage, and heat. Keep cables as far away as possible from equipment electric cables, particularly power cables to and from generators and electric motors; also avoid:
 - Antennas and associated cables
 - Fire hazard areas
 - Areas exposed to mechanical damage
 - Proximity to moving parts
 - Areas subject to debris accumulation
 - Areas exposed to high temperatures (turbo chargers, exhaust equipment, etc.)
 - Areas requiring access by equipment service and maintenance personnel
3. Select appropriate cable lengths for area of installation. See Section 2 - Components, page 2-6, for available sizes. Maximum circuit current rating is 1.5A.

Power Circuit Cables (Green Connectors)

Connects CHECKFIRE 210 ICM to 12/24 VDC nominal external power source using the Power Circuit Cable and the Fused Power Circuit Cable (connects to external power supply).

1. Determine location of power source that will provide the following current load capabilities.

SYSTEM CURRENT DRAW*

Nominal 6 mA @ 10.2 VDC

- Maximum Alarm/Fault 80 mA @ 10.2 VDC

Nominal 6 mA @ 28.0 VDC

- Maximum Alarm/Fault 35 mA @ 28.0 VDC

*Does not include AUX OUTPUT load of up to 1.5 A

2. Plan route for the Power Circuit Cable from the ICM module to the end point of the Fused Power Circuit Cable (note end points for both cables). Choose a path in accessible locations providing protection from undue wear, damage, and heat. Keep the cables as far away as possible from equipment electric cables, particularly power cables to and from generators and electric motors; also avoid:
 - Antennas and associated cables
 - Fire hazard areas
 - Areas exposed to mechanical damage
 - Proximity to moving parts
 - Areas subject to debris accumulation
 - Areas exposed to high temperatures (turbo chargers, exhaust equipment, etc.)
 - Areas requiring access by equipment service and maintenance personnel
3. Select appropriate cable lengths for area of installation. See Section 2 - Components, page 2-7, for available sizes.

Optional Discharge Pressure Switch Assembly

Install switch in expellant gas actuation line next to inlet port on the agent tank. Make certain to protect switch and connections from potential damage.

The switch must be on a branch line in detection circuit #2 with an EOL Device completing the main trunk of the tee.

Note: Pressure switch activates on expellant gas release.

Label Package

Include a Label Package (Part No. 440798) to identify specific procedures of the system to equipment operators.

System Layout

Once components are selected and locations are determined, complete a final drawing of the system layout. This drawing should at a minimum include the following:

- Hazard area locations
- Component locations (include external power source)
- Routes for all connecting circuits with cable lengths identified.

Indicate areas where cable must pass-through bulkheads. Use circuit bulkhead connectors to support and protect cables. (Confirm acceptable pass-through locations with vehicle/equipment manufacturer.) The drawing should be as precise as possible to avoid installation problems later.

Compile a list of components to confirm system includes all required parts (review Planning Checklist Template, page 4-11). The CHECKFIRE System is complete when all necessary components combine to provide automatic fire detection and activation of the fire suppression system for protected areas.

PLANNING CHECKLIST TEMPLATE
(Copy before use)

Components

- CHECKFIRE 210 Display Module
- Mounting Bracket
- Display Cable
- CHECKFIRE 210 Interface Control Module
- Detection Circuit Cable(s), Tees, EOL Device, and Branch Terminator(s)
- Electric Manual Actuator(s) (EMA) and Bracket(s)
- Linear Detector(s)
- Spot Thermal Detector(s) (include bracket and heat shield), if applicable
- Release Circuit Cable(s) and Tees
- Release Circuit Drop Cable(s)
- PAD(s)
- Electric-Pneumatic Actuator(s) (may be supplied with agent tanks)
- Pneumatic Manual Actuator(s) (optional)
- Relay Circuit #1 and #2 Cable(s)
- Auxiliary Output Cable(s)
- Power Circuit Cable(s) and Fused Power Circuit Cable
- Pressure Switch(es), if applicable
- Rubber-Coated 5/16 in. (8 mm) P-Clamps (by others)
- Double-Loop Cable Ties
- Bulkhead Connectors (display, detection, release, and power circuits)
- Alarms and/or Strobes
- Label Package

Note: For part numbers, see Section 10 – Appendix, Component Index, page 10-1.

Programming Options

(Certain options will affect availability of other options)

Pressure Switch Feedback (PSF)

- Disabled (default)
- Enabled, uses Detection Circuit #2 for pressure switch input.
 - Enable auto-release activation of PAD(s)

Note: Cross-Zone not available

Cross-Zone Protection

- Disabled (default)
- Enabled, Detection Circuit #1 and #2 are independent detection and both must detect alarm condition to start time delays.

Note: Pressure Switch Feedback not available

Detection Circuit #1 (Cross-Zone disabled)

- Independent detection/release (default)
- Detection (Alarm Only)

Detection Circuit #2 (Cross-Zone disabled)

- Independent detection/release (default)
- Detection (Alarm Only)

Detection Circuit #2 (Pressure Switch Feedback enabled)

- Alarm Only (default)
- Release activation (PADs)

Time Delay #1 (Seconds)

- 0
- 5
- 10 (default)
- 15

Time Delay #2 (Seconds)

- 0
- 5
- 10 (default)
- 15

Time Delay #1 (Restarts)

- 2 (default)
- Unlimited

Relay Circuit #1

- Alarm (default)
- Fault

Relay Circuit #2

- Shutdown (default)
- Alarm

NOTES:

INSTALLATION

Before installing the CHECKFIRE 210 Detection and Actuation System, Section 4 - System Planning should be studied in its entirety. In addition, a resulting system layout drawing with information on hazard areas, component locations, and routing of connecting circuits, along with all cable lengths identified, should be available. Review this drawing and become familiar with all applicable steps and instructions before installing any component.

NOTICE

For ease of installation, the fire suppression system should be installed before the detection and actuation system.

CHECKFIRE 210 DISPLAY MODULE INSTALLATION

The CHECKFIRE 210 Display Module may be surface mounted (3/16 in. (4.7 mm) maximum thickness) or bracket mounted. For bracket mounting, use the CHECKFIRE 110/210 Mounting Bracket (Part No. 439564). Index pins on the display module prevent rotating. **Note:** The display module should never be mounted in an area subject to pressure washing or steam cleaning.

Surface Mounting Instructions

Although recommended, the CHECKFIRE 210 Display Module does not require a bracket when surface mounting in a flat location. The location must properly support the display module during all vehicle/equipment environmental and operating conditions (e.g., shock and vibration).

1. Refer to layout drawing for planned location and determine a position within operator's reach with the best viewing angle for display module LEDs and easy access to display module buttons. Verify the location meets approval of the vehicle/equipment owner and/or vehicle/equipment service manager.
 2. Confirm access to underside or rear of mounting surface to enable proper cable connections, periodic inspections, and maintenance. Verify display module location and connections will not interfere with normal vehicle/equipment operation, service, and maintenance.
 3. Drill three holes matching the correct diameter and layout for surface mounting, see Figure 5-1.
 - a. Use the foam gasket as a template to carefully mark hole locations. The gasket has 4 index holes (for ease of installation) and the display module has 2 index pins. Before drilling, make sure index holes on the gasket line up correctly with the index pins on the display module. See Figure 5-2.
- Note:** The foam gasket is packaged in a separate bag with the enclosure nut, rubber washer, and visual seal in the CHECKFIRE 210 Shipping Assembly (Part No. 439559).
- b. After drilling holes, remove burrs and sharp edges.

4. Install foam gasket on display module.
 - a. Remove protective backing exposing gasket adhesive.
 - b. Align with index pins on back of display module and press in place, securing to display module surface.

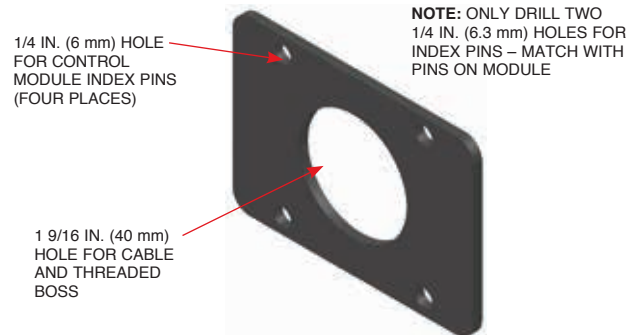

FIGURE 5-1
SURFACE MOUNTING TEMPLATE (FOAM GASKET)
00920

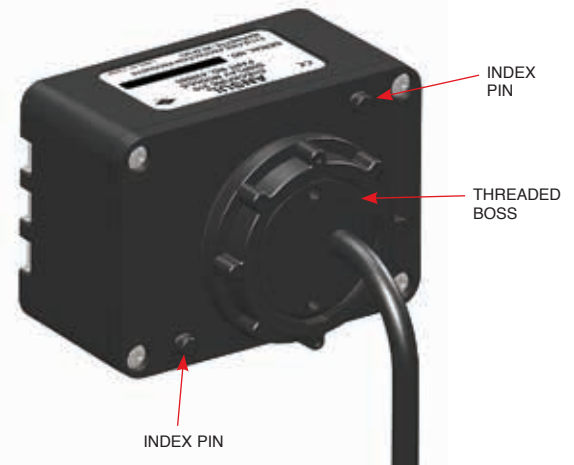

FIGURE 5-2
INDEX PINS AND THREADED BOSS
009303

5. If possible, hold rubber washer and enclosure nut (packaged in separate bag) on the back side of the mounting surface so it lines up with the 1 9/16 in. (40 mm) drilled hole.
6. Carefully feed cables through drilled hole, rubber washer, and enclosure nut.
7. Fit index pins and threaded boss into the drilled holes.

Surface Mounting Instructions (Continued)

- Hand-tighten enclosure nut on threaded boss, see Figure 5-3.

NOTICE

Only hand-tighten enclosure nut, do not use mechanical force such as a wrench.



FIGURE 5-3
SURFACE MOUNT 210 DISPLAY MODULE

009304/009305/009306

Bracket Mounting Instructions

Bracket mounting requires the CHECKFIRE 110/210 Mounting Bracket (Part No. 439564). The bracket is a two piece, multi-position bracket for securing the display module in a variety of configurations. Mount on a flat surface that will properly support the display module during all vehicle/equipment operating and environmental conditions (e.g. shock and vibration).

The bracket includes a Bracket Base, a Swivel Mount and two swivel joint screws, see Figure 5-4. The display module attaches to swivel mount in a horizontal or vertical position on either side of swivel mount.

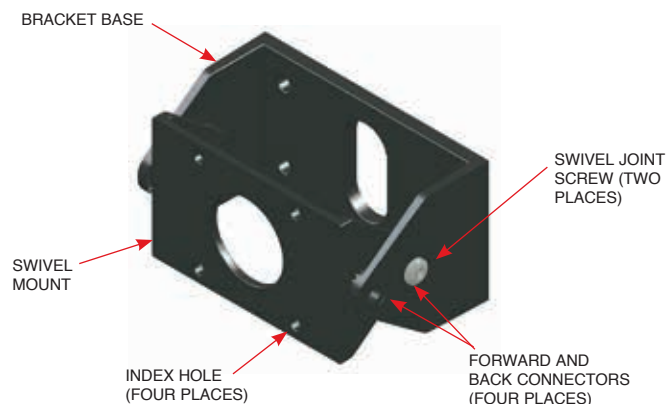
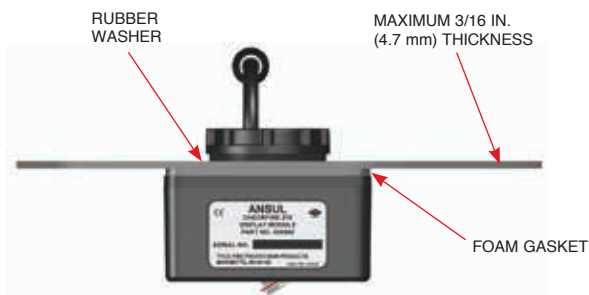

FIGURE 5-4
CHECKFIRE 110/210 MOUNTING BRACKET

009181

- Refer to layout drawing for planned location and determine a position within the operator's reach with the best viewing angle for display module LEDs and easy access to display module buttons. Verify the location meets approval of the vehicle/equipment owner and/or vehicle/equipment service manager. See Figure 5-5 for sample mounting options. Note the positions of swivel mount and connectors.



Bracket Mounting Instructions (Continued)



INSET SWIVEL MOUNT

ANGLED BASE



FULL EXTENSION

VERTICAL BASE, CONTROL
 MODULE AT 90 DEGREES



EXTENDED SWIVEL MOUNT
 IN BACK CONNECTORS

VERTICAL BASE, INSET
 SWIVEL MOUNT

**FIGURE 5-5
 SAMPLE MOUNTING OPTIONS**

009307/009308/009309

2. Confirm access to the display module for proper cable connections, periodic inspections, and maintenance. Verify module location and connections will not interfere with vehicle/equipment operation, service, and maintenance.
3. Using the bracket base as a template (see Figure 5-6), mark and drill 9/32 in. (7 mm) holes in the flat surface (4 places).
4. If needed, mark a 1 5/8 in. (42 mm) dia. circle in the mounting surface, matching center of the 7/8 in. x 1 3/4 in. (22 mm x 44 mm) opening for cables passing through the mounting surface. See Figure 5-6. Drill the marked hole. Remove burrs and sharp edges; protect cables as needed.

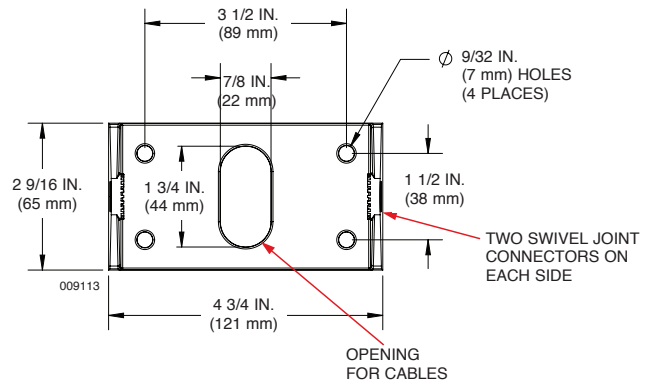

**FIGURE 5-6
 BRACKET BASE FRONT VIEW**

009113

5. Secure base to mounting surface using appropriate length fasteners (1/4 in. (6 mm) screws or bolts with lock washers and nuts).
6. Attach display module to swivel mount according to the position determined in Step 1.
 - a. Retrieve enclosure nut and rubber washer for threaded boss from separate bag in the CHECKFIRE 210 Shipping Assembly (Part No. 439559).
 - b. Carefully feed cables through center hole in Swivel Mount, rubber washer, and enclosure nut.
 - c. Insert index pins into index holes and hand-tighten enclosure nut to threaded boss. See Figure 5-7.

Bracket Mounting Instructions (Continued)

NOTICE

Only hand-tighten enclosure nut, do not use mechanical force such as a wrench.

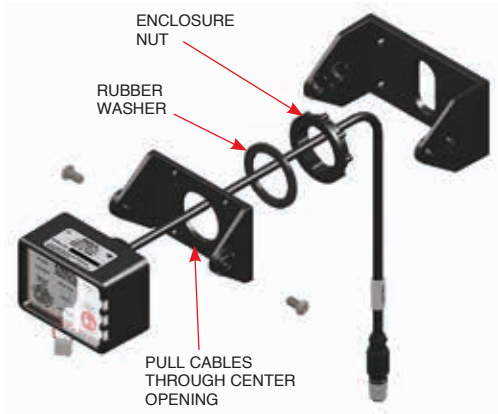

**FIGURE 5-7
 ENCLOSURE NUT**
 009310

- If required, feed cables through opening in bracket base. Reinstall the Swivel Mount to the base according to the position determined in Step 1. Carefully align joint teeth and secure with the swivel joint screws to lock swivel mount in place. Do not over tighten, 20-25 in-lbs (2.26-2.82 N•m) maximum. See Figure 5-8.

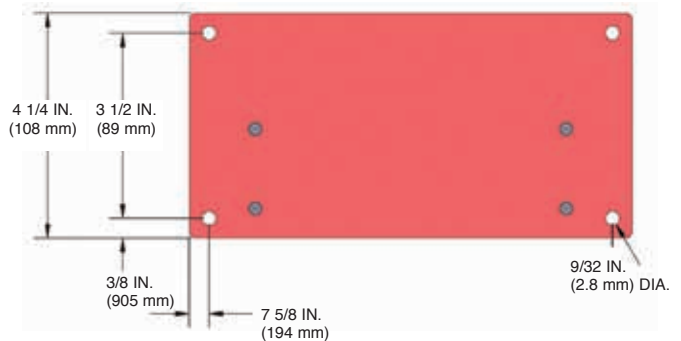

**FIGURE 5-8
 MOUNTING BRACKET WITH
 CHECKFIRE 210 DISPLAY MODULE**
 009311

MOUNTING INTERFACE CONTROL MODULE (ICM)

Mount on a flat surface that will properly support the ICM during all vehicle/equipment operating and environmental conditions (e.g. shock and vibration).

- Refer to layout drawing for planned location. Verify the location meets approval of the vehicle/equipment owner and/or vehicle/equipment service manager.
- Confirm access to the ICM for proper cable connections, periodic inspections, and maintenance. Verify module location and connections will not interfere with vehicle/equipment operation, service, and maintenance.
- Using the ICM mounting plate as a template (see Figure 5-9), mark and drill 9/32 in. (7 mm) holes in the flat surface (4 places).
- Secure ICM to mounting surface using appropriate length fasteners (1/4 in. (6 mm) screws or bolts with lock washers and nuts).



**FIGURE 5-9
 SURFACE MOUNTING**
 009273 / 009312

CABLE CONNECTIVITY / INSTALLATION

The CHECKFIRE 210 System utilizes IP67 circular threaded connectors on all cable and tee components. This modular cable harness reduces installation time and damaged cables can be replaced without replacing the entire cable assembly.

The cable assemblies have a red outer jacket between threaded connectors.

For easy recognition of each cable type, the integral connectors have color-coded overmolding. Specific pin and key designs help ensure proper cable connections.

Note: Refer to the layout drawing for circuit routing and cable/tee assembly.

CIRCUIT CABLE IDENTIFICATION

Circuit	Color	Pins
Detection #1	RED	4
Detection #2	RED	4
Display	BLACK	5
Release	BLUE	2
Relay #1 & #2	YELLOW	6
Auxiliary Output	GREEN	2
External Power	GREEN	2

Connector Assembly

Organize cables, tees, and associated connectors for each circuit. Assemble cables by connecting the male and female connectors. The male end has connector pins and a threaded swivel nut. The female end has sockets and a swivel connector, see Figure 5-10.

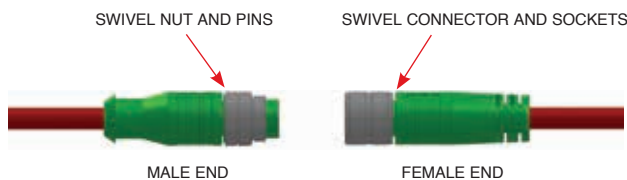

FIGURE 5-10
CABLE CONNECTORS
009208

1. Align the male end with the female end by positioning keyed slots and pins in the proper orientation, see Figure 5-11.

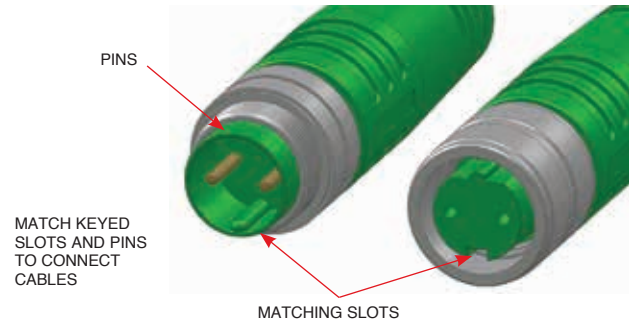

FIGURE 5-11
ALIGN PINS AND KEYS
009209

2. Lightly press connectors together while rotating until the keys align. Then firmly press connectors together while threading swivel nut; hand-tighten only. If connectors do not go together easily, do not force; recheck keyed slots and pins to ensure proper alignment. **Note:** May need to press connectors together repeatedly and tighten until firmly seated.
3. When tight, grasp connectors, push together firmly, then re-tighten swivel fittings.
4. These steps are also used when connecting the cable connectors to the bulkhead style receptacles on the ICM.

NOTICE

Do not use mechanical force such as a wrench. The connection has an IP67 rating when hand-tightened and does not require mechanical force.

General Instructions for Cable Installation

All cable assemblies, regardless of type (e.g., detection, release, power), must be supported with rubber-coated 5/16 in. (8 mm) P-Clamps or double-loop cable ties (Part No. 440737) attached to the vehicle/equipment. The minimum bend radius for all cable assemblies is 2 1/2 in. (64 mm).

When installing cable assemblies, keep the cables as far away as possible from vehicle/equipment electric cables, particularly power cables to and from generators and electric motors; also avoid:

- Antennas and associated cables
- Fire hazard areas
- Areas exposed to mechanical damage
- Proximity to moving parts
- Areas subject to debris accumulation
- Areas exposed to high temperatures (turbo chargers, exhaust equipment, etc.)
- Areas requiring access by vehicle/equipment service and maintenance personnel

General Instructions for Cable Installation (Continued)

Confirm cables are not subject to damage and will not interfere with vehicle/equipment service and maintenance procedures.

1. Follow planned route in the layout drawing and install each circuit starting at the ICM receptacle and work outward. Completely install one circuit at a time, finishing with the power circuit. Use correct size P-Clamps to avoid problems, see Figure 5-12. **Note:** Changes to the planned route will likely alter cable lengths needed for installation.

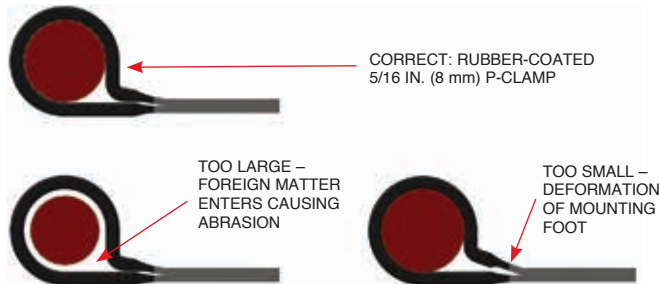

FIGURE 5-12
USE CORRECT SIZE P-CLAMPS
 009210

2. If attachment points are not available for P-Clamps, a double-loop cable tie (Part No. 440737) is acceptable for support and separation between cables and the securing point. **Note: Cables should not be supported by hydraulic hoses.** See Figure 5-13.

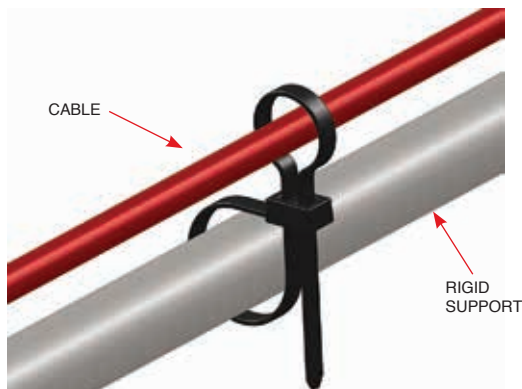

FIGURE 5-13
DOUBLE-LOOP CABLE TIE
 009211

3. Secure cables at least every 3 ft (0.9 m) and within 1 ft (0.3 m) on both sides of connectors or connection to a device. See Figure 5-14.

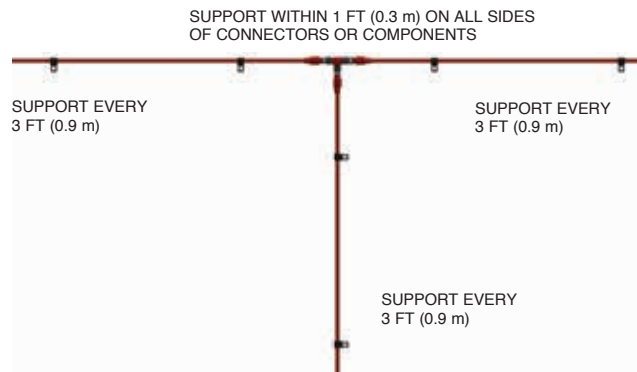

FIGURE 5-14
CABLE SUPPORT REQUIREMENTS
 009212

4. Adjust slack to avoid droops in cable. Allow appropriate slack through areas that are intended to move under normal vehicle/equipment operation.
5. When cables pass through a partition, it is recommended to use a bulkhead connector designed for the appropriate cables. **Note: Cables must never be routed through a hole or near sharp edges without being properly protected.** See Figure 5-15.

Bulkhead Connectors

Part No.	Maximum Pass-through Thickness	Cable Type
439404	3/8 in. (9.5 mm)	Detection Circuit
439405	1 in. (25 mm)	Release Circuit Power Circuit Aux. Output Circuit
439449	3/8 in. (9.5 mm)	Display Circuit



DETECTION CIRCUIT



RELEASE CIRCUIT, POWER CIRCUIT, AND AUX. OUTPUT CIRCUIT



DISPLAY CIRCUIT

FIGURE 5-15
BULKHEAD CONNECTORS
 009159/009166

► LINEAR DETECTOR INSTALLATION

Install Linear Detector throughout the hazard area by connecting directly to the main detection circuit trunk. **Note: Linear Detector should not be supported by hydraulic hoses.**

NOTICE

The minimum bend radius for Linear Detector must not be less than 2 1/2 in. (64 mm) (see Figure 5-17, page 5-8). Adjust slack to avoid droops in cable. Allow appropriate slack through areas that are intended to move under normal vehicle/equipment operation.

- Do not try to stretch Linear Detector in any way.
- Do not attach Linear Detector to commonly removed or replaced equipment.

Note: Linear Detector must connect to main detection circuit trunk, not the branch line of a Detection Circuit Tee.

Maximum total length of Linear Detector plus Detection Circuit Main Trunk is 750 ft (228.6 m). For example: If Detection Circuit Cable is 50 ft (15.24 m), then Linear Detector could be up to 700 ft (213.4 m).

Keep the following in mind when installing a Linear Detector:

- Make certain Linear Detector routing allows direct exposure to heat resulting from a fire
- Choose routing locations where heat is likely to travel to or through quickly in event of a fire
- Maximum installed ambient temperature at the Linear Detector location is 250 °F (121 °C).
- Support Linear Detector from mounting surfaces such as decks, struts, framework, vehicle/equipment component support, or support structures, etc., always keeping system planning guidelines and vehicle/equipment maintenance procedures in mind. **Note:** When supporting from the vehicle/equipment make certain any support device requiring drilling or welding is approved by owner or vehicle/equipment manufacturer.
- Avoid securing Linear Detector too close to extremely hot components
- Route the Linear Detector where it will not be subject to damage and not interfere with vehicle/equipment maintenance procedures.
- Keep Linear Detector as far away as possible from vehicle/equipment electric cables, particularly power cables to and from generators and electric motors.

1. Make sure detection circuit cable is completely installed from CHECKFIRE 210 ICM to hazard area end point. Start installation of Linear Detector at end point of detection circuit cable.
2. Install Linear Detector above hazard area or around perimeter of a hazard compartment so it can react to escaping heat. Refer to layout drawing. Do not allow struts, frame members, or other obstacles to act as heat shields between hazard and detector cable.
3. Do **NOT** install Linear Detector within 12 in. (305 mm) of any area that will become extremely hot during operation, such as:
 - Engine blocks
 - Exhaust manifolds
 - Exhaust tubes/mufflers
 - Turbochargers
4. Secure Linear Detector every 12 in. to 18 in. (305 mm to 454 mm) using appropriately sized (5/16 in. (8 mm)) rubber-lined P-Clamps. Where it is not possible to use rubber lined P-Clamps, a double-loop cable tie (Part No. 440737) and protective covering (Part No. 56692) is acceptable to provide separation between cable and securing point. Secure more often if necessary

Slice rubber tube length wise to fit around the Linear Detector. This protective covering should also be used at locations where cable would rub against other hard surfaces, rough edges, or sharp corners. See Figure 5-16.

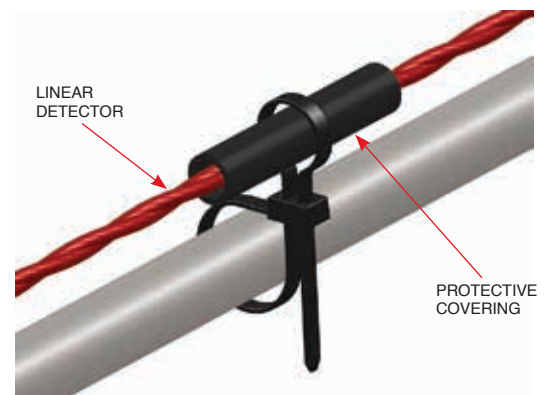

FIGURE 5-16
DOUBLE-LOOP CABLE TIE

009213

► LINEAR DETECTOR INSTALLATION (Continued)

- When a Linear Detector must pass-through a partition it is recommended to use a bulkhead fitting designed for the appropriate cable. See Figure 5-15, page 5-6.

Bulkhead Connector

Part No.	Maximum Pass-through Thickness	Cable Type
439404	3/8 in. (9.5 mm)	Detection Circuit

CAUTION

Linear Detector must never be routed through a hole or near sharp edges without being properly protected. Failure to protect the cable from being cut or abraded could cause a fault condition or false alarm condition, potentially leading to a false activation or detection failure.

- Install an EOL Device (Part No. 439396) at end of the Linear Detector, if last device, to complete the circuit. See Figure 5-17.

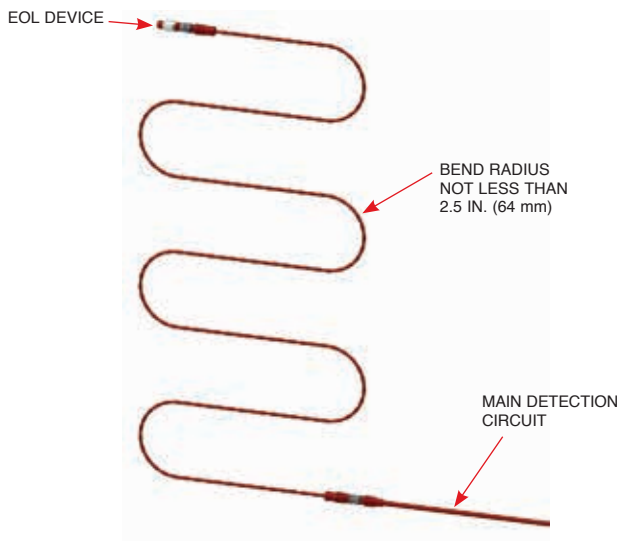

FIGURE 5-17
SAMPLE LINEAR DETECTOR INSTALLATION
 009194

► SPOT THERMAL DETECTOR INSTALLATION

Mount in a location where detector head points in a downward position with exposure over the hazard area (refer to layout drawing).

- Attach Spot Thermal Detector Bracket securely to mounting surface by welding or bolting with two 1/4 in. bolts of appropriate length (secure with lock washers and nuts). See Figure 5-18. **Note:** When supporting from the vehicle/equipment make certain any support device requiring drilling or welding is approved by owner or vehicle/equipment manufacturer.
- After securing bracket, remove retaining nut from detector head and slide detector in bracket. Confirm detector has male/female connectors in correct position for connection to detection circuit cable. See Figure 5-19.

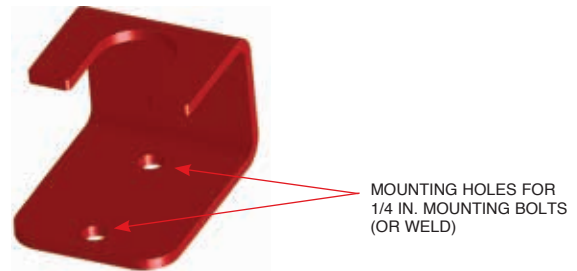

FIGURE 5-18
SPOT THERMAL DETECTOR BRACKET
 009234

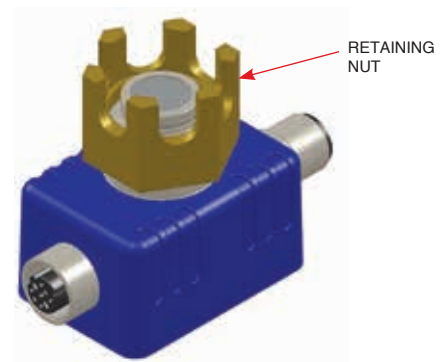

FIGURE 5-19
SPOT THERMAL DETECTOR
 009280

► SPOT THERMAL DETECTOR INSTALLATION (Continued)

3. Place Heat Shield over detector head and loosely install retaining nut. See Figure 5-20. Note: Remove Heat Shield to connect Detection Circuit Cables.

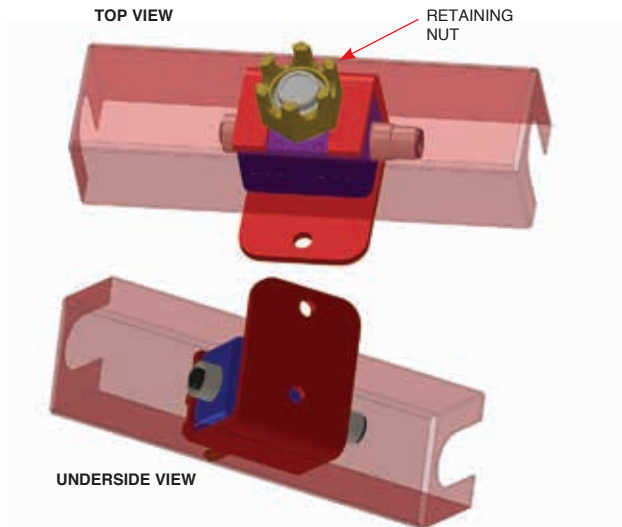

FIGURE 5-20
DETECTOR IN BRACKET WITH HEAT SHIELD

009214

4. During final installation, apply a medium-strength thread-locking compound (e.g., LOCTITE THREADLOCKER BLUE 242) to the base of threaded detector head near the heat shield.
5. Tighten retaining nut wrench-tight until the retaining nut is snug. Do not over tighten. Torque not to exceed 25 in-lb (2.82 N·m).

CAUTION

Over tightening of the retaining nut can damage the detector. Do not over-tighten. Torque not to exceed 25 in-lb (2.82 N·m).

RETRO-FIT INSTALLATION

For a retro-fit installation, install spot thermal detector bracket directly onto existing style detector bracket (Part No. 416221). See Figure 5-21.

1. Remove 1/4-20 x 5/8 in. socket head screws from existing detector bracket and retain. Remove installed spot thermal detector needing replacement and cable clamp on each end.
2. Align replacement Spot Thermal Detector Bracket mounting holes with the holes in the existing bracket and re-install socket head screws.
3. Install replacement Spot Thermal Detector and Heat Shield as in steps 2 – 5 above.

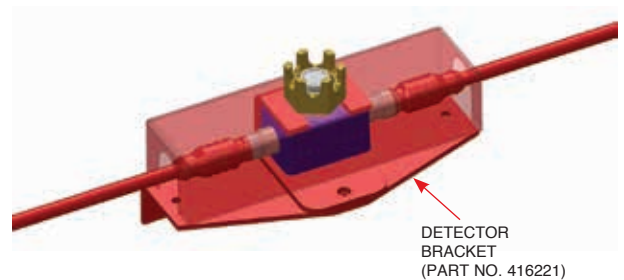

FIGURE 5-21
RETRO-FIT INSTALLATION

009215

ELECTRIC MANUAL ACTUATOR (EMA) INSTALLATION

Refer to layout drawing and install Electric Manual Actuator at location(s) in a path of operator egress and accessible from ground level, when possible. Confirm Detection Circuit Tee for the EMA is prior to any detection device in the main detection circuit trunk.

EMA may be surface (1/4 in. (6.3 mm) maximum thickness) or bracket mounted. For bracket mounting use the EMA Bracket (Part No. 440537).

Surface Mounting Instructions

1. Drill a 1 9/16 in. (40 mm) hole in selected surface (always deburr and smooth edges of hole). See Figure 5-22. **Note:** When supporting from the vehicle/equipment make certain any support device requiring drilling or welding is approved by owner or vehicle/equipment manufacturer.

**ELECTRIC MANUAL ACTUATOR (EMA) INSTALLATION
 (Continued)**

- Determine position and add keyway for EMA orientation index nub. See Figure 5-22.

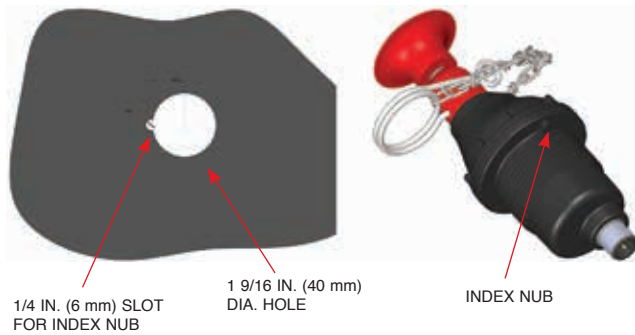
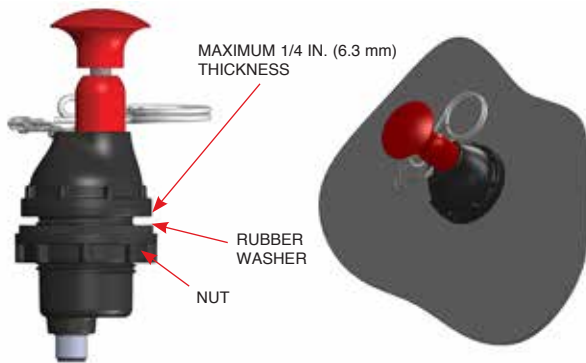

**FIGURE 5-22
 EMA SURFACE MOUNT DIMENSIONS**
 009216

- Remove nut and rubber washer from threaded boss and insert boss through drilled hole fitting index nub into slot. Install rubber washer and hand-tighten nut on threaded boss. See Figure 5-23.

NOTICE

Only hand-tighten nut, do not use mechanical force such as a wrench.

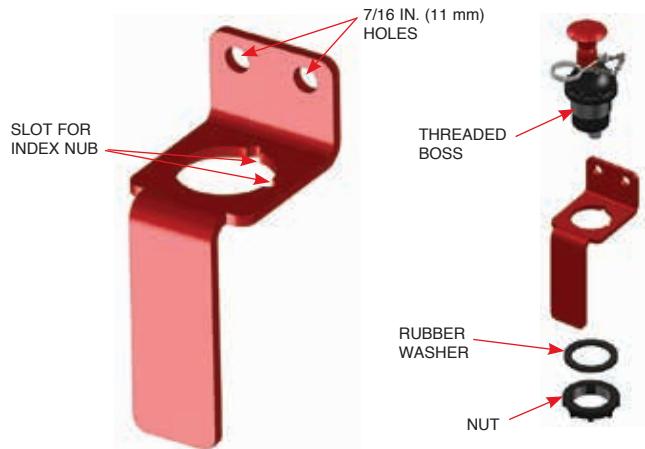

**FIGURE 5-23
 EMA SURFACE MOUNT INSTALLED**
 009217

Bracket Mounting Instructions

The bracket has a 1 9/16 in. (39.7 mm) hole for mounting the EMA.

- Install the EMA Bracket (Part No. 440537) by either bolting or welding. **Note:** When supporting from the vehicle/equipment make certain any support device requiring drilling or welding is approved by owner or vehicle/equipment manufacturer.
 - Bolting:** Using bracket base as a template (see Figure 5-24), mark and drill 7/16 in. (11 mm) holes in flat surface (2 places). Secure bracket with 3/8 in. (9 mm) corrosion resistant bolts of the appropriate length with lock washers and nuts.
 - Welding:** Confirm intended surface is approved for welding. To avoid corrosion, paint welded surfaces after welding is complete and surface temperature is normal.



**FIGURE 5-24
 EMA BRACKET MOUNT**
 009218

- Once the EMA bracket is securely mounted, remove nut from threaded boss on EMA. Position EMA in bracket with RED strike button facing in desired direction (fit index nub into desired slot). Install rubber washer and hand-tighten nut on threaded boss. **Note:** Pull pin may need to be removed and inserted in the opposite direction for proper fit. See Figure 5-25.

NOTICE

Only hand-tighten nut, do not use mechanical force such as a wrench.

Note: Install visual seal (supplied by others) when instructed in Section 6 - Operational Test and Place in Service.

Bracket Mounting Instructions (Continued)

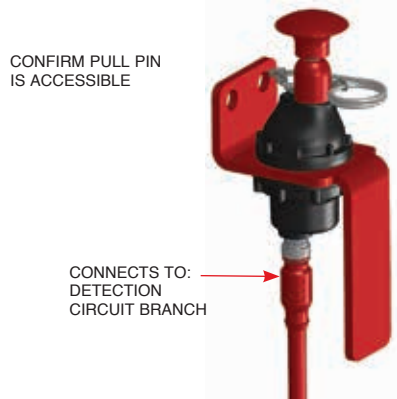

FIGURE 5-25
EMA INSTALLED IN BRACKET
009219

ELECTRIC-PNEUMATIC ACTUATOR INSTALLATION

The Electric-Pneumatic Actuator (Part No. 439569) installs on an expellant gas cartridge and can be used as an electronic and/or pneumatic actuation device, see Figure 5-26. The actuator includes a preventor to reduce the possibility of installing actuator with the puncture pin not completely retracted, see Figure 5-27. Do not bend or remove the preventor; it is required for correct operation of the actuator.

The CHECKFIRE 210 System can actuate a maximum of ten Electric-Pneumatic Actuators.

Visually confirm lubrication of the upper o-ring and push puncture pin down several times to confirm ease of movement. Make sure pin is completely retracted.

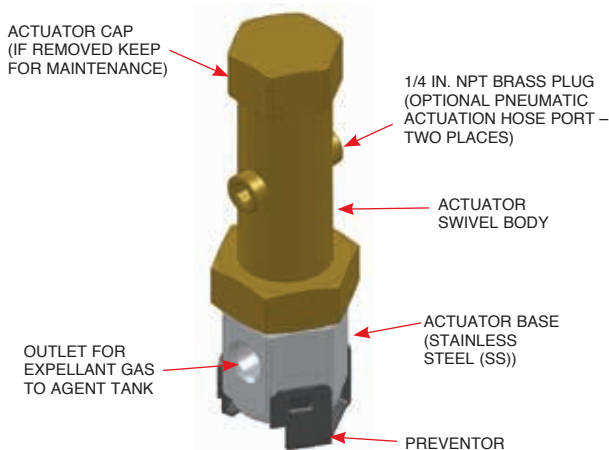

FIGURE 5-26
ELECTRIC-PNEUMATIC ACTUATOR
009168

WARNING

Before attaching Electric-Pneumatic Actuator to expellant gas cartridge, verify the cartridge is properly secured and confirm puncture pin is in the completely retracted position. See Figure 5-27. If puncture pin is not completely retracted, the seal can become damaged or pierced, which can result in system actuation or serious personal injury or death.

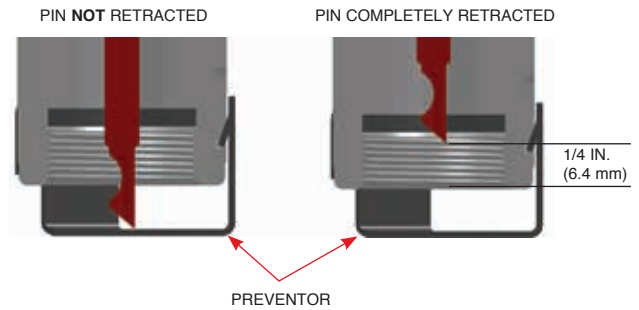

FIGURE 5-27
RETRACT ACTUATOR PUNCTURE PIN
009220

1. To install the actuator, slide the unit onto the expellant gas cartridge from the side. (Cartridge must be properly secured.) Slide preventor underneath cartridge threads and thread actuator on cartridge. See Figure 5-28.

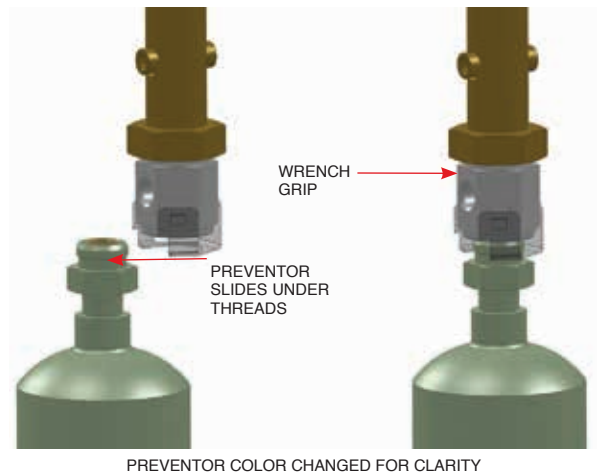

FIGURE 5-28
SLIDE ACTUATOR ONTO CARTRIDGE
009221

2. Wrench-tighten actuator base (SS) to cartridge. **Note:** Wrench grip is above preventor. See Figure 5-28.
3. Turn cartridge in cartridge bracket (loosen as needed) so expellant gas outlet is in desired orientation, then re-secure cartridge in bracket.

**ELECTRIC-PNEUMATIC ACTUATOR INSTALLATION
 (Continued)**

4. Position actuator swivel body in desired orientation and wrench-tighten to actuator base until preventor is held tight in place. See Figure 5-29.

CAUTION

DO NOT ATTACH CABLE TO ELECTRIC-PNEUMATIC ACTUATOR UNTIL TESTING IS COMPLETE.

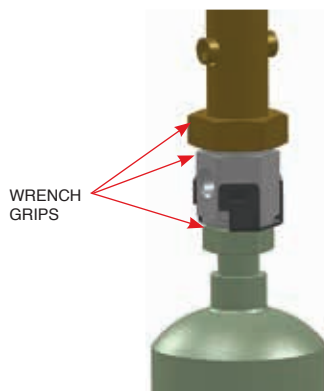

**FIGURE 5-29
 ACTUATOR INSTALLED ON CARTRIDGE**
 009222

DETECTION CIRCUIT CABLES

The Detection Circuit #1 and #2 Receptacles (red ID rings) on the CHECKFIRE 210 ICM are starting points for detection circuits. See Figure 5-30. Each Detection Circuit consists of a main trunk and may add branch lines utilizing Detection Circuit Tees on the main trunk.

Route and secure the Detection Circuit Cable following the installation instructions under Cable Connectivity / Installation, page 5-5.

Maximum total length of Detection Circuit Main Trunk plus Linear Detector is 750 ft (228.6 m). For example: If Detection Circuit Cable is 50 ft (15.24 m), then Linear Detector could be up to 700 ft (213.4 m). Maximum length for individual branch lines is 250 ft (76 m) (not included with main trunk limit).

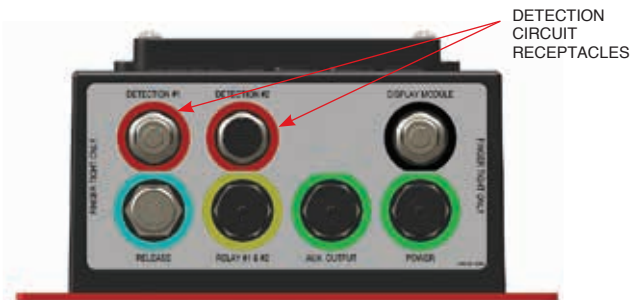

**FIGURE 5-30
 ICM RECEPTACLES**
 009314

Verify each cable route (#1 and/or #2) from the ICM to the detection component end points conforms to the following rules (see Figure 5-31):

- Detection Circuit Tees can only be installed on the main trunk
- No Double Branching
- No EOL Devices on end of branch
- Branch line must end with Detection Circuit Branch Terminator or EMA
- EMAs must be first component(s) on circuit if used
- Each EMA must be on a single use branch line
- Linear Detector may be anywhere in the main trunk after the EMA
- Main detection circuit trunk must be terminated with EOL Device



**FIGURE 5-31
 SAMPLE - CORRECT DETECTION CIRCUIT INSTALLATION**
 009293

Install Detection Circuit(s) using the following rules:

1. An Electric Manual Actuator (EMA), if used, must be installed prior to any other detection device. Install a Detection Circuit Tee and required length of Detection Circuit Cable. See Figure 5-32.
2. Install each EMA on a separate branch (only one device on a branch). See Figure 5-32.
3. Spot Thermal Detectors can be installed in main trunk of detection circuit or on a branch circuit using a Detection Circuit Tee and Detection Circuit Cable. If installed on a branch circuit, a Detection Circuit Branch Terminator (Part No. 439398) must be connected to the last detector. See Figure 5-33.

CAUTION

Do not terminate any branch with an EOL Device. Use Branch Terminator only.

4. The Linear Detector may be installed anywhere in the main detection circuit trunk after EMA. If last device, the Linear Detector is terminated with an EOL Device. See Figure 5-34.

DETECTION CIRCUIT CABLES (Continued)



FIGURE 5-32
DETECTION CIRCUIT - EMA
 009294

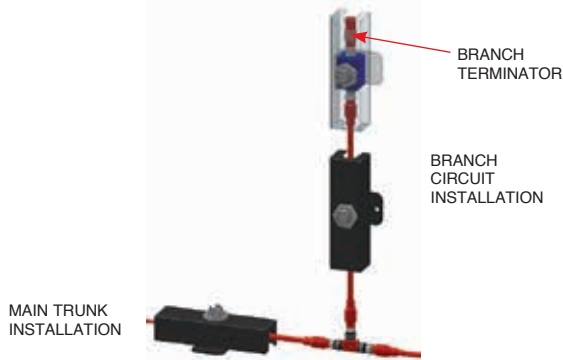

FIGURE 5-33
DETECTION CIRCUIT – SPOT THERMAL DETECTORS
 009223

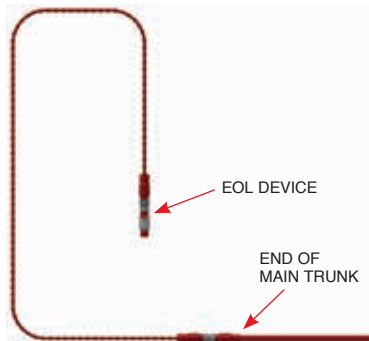

FIGURE 5-34
DETECTION CIRCUIT - LINEAR DETECTOR
 009224

Review complete installation to verify correctness. If any of the following **INCORRECT INSTALLATION** examples are found adjust as needed.

INCORRECT INSTALLATIONS

CAUTION

Do not use an EOL Device on a branch because complete detection circuit will not be monitored. (See Figures 5-35 and 5-36). Double branching is not allowed. (See Figures 5-35 thru 5-37). Failure to comply may cause the system to not function properly.



FIGURE 5-35
INCORRECT EMA AND EOL INSTALLATION
 009297



FIGURE 5-36
INCORRECT EMA AND EOL INSTALLATION
 009298

CAUTION

Only one EMA may be installed from a detection circuit tee on a single branch circuit. If multiple EMAs are to be installed, additional branches on the main trunk will be required (one EMA per branch). Incorrect installations will cause the system to not function properly. See Figure 5-37.



FIGURE 5-37
INCORRECT EMA INSTALLATION
 009299

DETECTION CIRCUIT CABLES (Continued)

INCORRECT INSTALLATIONS (Continued)

CAUTION

Install EMA(s) as the first component(s) on the Detection Circuit and on a single use branch. Failure to comply may cause the system to not function properly. (See Figure 5-38, and 5-39).



EMA MUST BE FIRST COMPONENT AND ON SINGLE USE BRANCH

**FIGURE 5-38
 INCORRECT EMA INSTALLATION**
 009300



EMA MUST BE FIRST COMPONENT

**FIGURE 5-39
 INCORRECT EMA INSTALLATION**
 009301

CAUTION

Do not install the Linear Detector on a branch. (See Figure 5-40). Failure to comply may cause the system to not function properly.



LINEAR DETECTOR MUST BE IN THE MAIN TRUNK, AND END WITH EOL DEVICE, IF LAST DEVICE ON MAIN TRUNK

**FIGURE 5-40
 INCORRECT LINEAR DETECTOR INSTALLATION**
 009302

DISPLAY CABLES

The Display Module Receptacle (black ID ring) on the CHECKFIRE 210 ICM is the starting point for the display circuit. See Figure 5-41.

The display circuit is a single cable providing circuit connection between the ICM and the CHECKFIRE 210 Display Module for communication of commands and system status. No tees or branches are allowed on this circuit.

Only one display module may be used on each CHECKFIRE 210 System.

Note: Display cable maximum length is 50 ft (15.24 m).



DISPLAY CIRCUIT RECEPTACLE

**FIGURE 5-41
 DISPLAY CABLE RECEPTACLE**
 009273

RELEASE CIRCUIT CABLES

The Release Circuit Receptacle (blue ID ring) on the CHECKFIRE 210 ICM is the starting point for the release circuit. See Figure 5-42. The Release Circuit consists of a main trunk, Release Circuit Tee(s) (if required), and Release Circuit Drop Cable(s). **Note:** Release Circuit maximum length is 250 ft (76.2 m).



RELEASE CIRCUIT RECEPTACLE

**FIGURE 5-42
 RELEASE CIRCUIT RECEPTACLE**
 009273

RELEASE CIRCUIT CABLES (Continued)

Install Release Circuit using the following rules (see Figure 5-43 and 5-44):

1. Maximum ten PADs.
2. Maximum length is 250 ft (76.2 m) of Release Circuit Cable. (Cable dimensions include the connectors.)
3. Use a Release Circuit Tee for each additional actuator. Additional Release Circuit Cable may be used after the tee if required.
4. Use Release Circuit Drop Cable at end of circuit for connection to the Electric-Pneumatic Actuator.
5. Route and secure Release Circuit Cable following installation instructions under Cable Connectivity / Installation, page 5-5. (Remove and discard dust cap on Release Circuit Receptacle.)
6. Do not attach Release Circuit Drop Cable to Electric-Pneumatic Actuator at this time. If Release Circuit Drop Cable is connected, the system could be accidentally actuated during installation.

CAUTION

DO NOT ATTACH ANY RELEASE CIRCUIT DROP CABLE TO ANY ELECTRIC-PNEUMATIC ACTUATOR UNTIL TESTING IS COMPLETE.

CAUTION

DO NOT ATTACH ANY RELEASE CIRCUIT DROP CABLE TO ANY ELECTRIC-PNEUMATIC ACTUATOR UNTIL TESTING IS COMPLETE.



FIGURE 5-44
RELEASE CIRCUIT - SINGLE TANK
009316

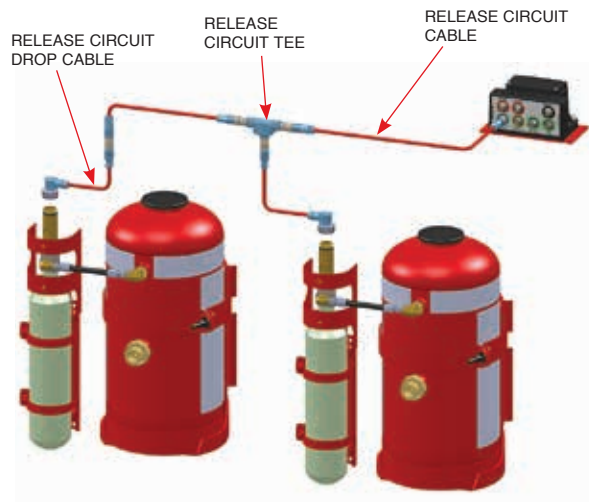

FIGURE 5-43
RELEASE CIRCUIT - TWO TANKS
009315

RELAY CIRCUIT CABLES

The Relay #1 & #2 Output Receptacle (yellow ID ring) on the CHECKFIRE 210 ICM is the starting point for the relay circuits. Each circuit provides connection points to contacts for two internal SPDT Form C relays. See Figure 5-45. The relays can be used to activate external notification devices or provide inputs to vehicle/equipment onboard monitoring systems. Connections to vehicle/equipment components are made by others.

Contact Rating for both relays: 30 VDC nominal at 6 amps.

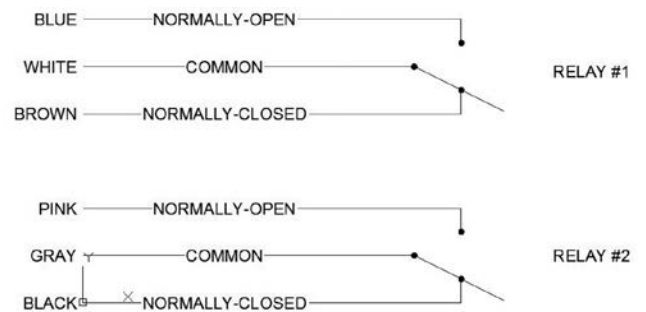

FIGURE 5-45
RELAY CIRCUIT CONDUCTORS
009317

AUXILIARY OUTPUT CABLES

The Auxiliary Output Receptacle (Green ID ring) on the CHECKFIRE 210 ICM is the starting point of the Auxiliary Output Power Circuit.

The auxiliary output circuit is powered by feedthrough of 12/24 VDC @ 1.5 A nominal provided from external power supply.

The Circuit is disabled when the CHECKFIRE 210 System is operating on the internal power supply.

Connections to equipment components are made by others.

POWER CIRCUIT CABLES

The Power Circuit Receptacle (green ID ring) on the CHECKFIRE 210 ICM is the starting point of the external power circuit. See Figure 5-46.



**FIGURE 5-46
 POWER CIRCUIT RECEPTACLE**
 009273

The power circuit consists of Power Circuit Cable(s) and a Fused Power Circuit Cable. See Figure 5-47.

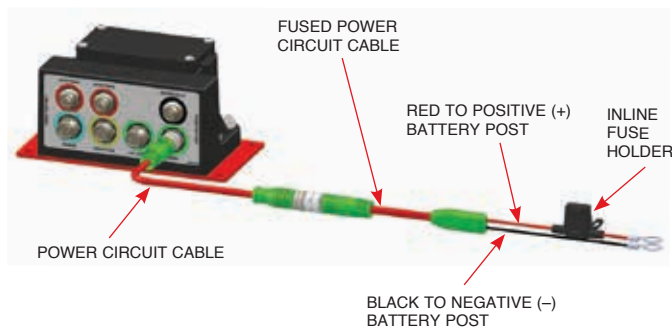

**FIGURE 5-47
 POWER CIRCUIT**
 009318

Before installation remove fuse and place in a safe place. Install power circuit using the following rules:

1. It is recommended to install power circuit directly to the 12/24 VDC nominal vehicle battery(s), if possible. This will provide continuous power for 24 hour system protection.
2. Install 1/2 in. (13 mm) ring terminal on black jacketed conductor, labeled “- VEH BATT” to the negative post on battery or 12/24 VDC nominal power source.
3. Install 1/2 in. (13 mm) ring terminal on red jacketed, 3A fused conductor, labeled “+ VEH BATT” to the positive post on the battery or 12/24 VDC nominal power source. **Do not install fuse at this time.**
4. Route and secure the Power Circuit Cable following the installation instructions under Cable Connectivity / Installation, page 5-5.
5. Do not install fuse until entire system is ready for testing (refer to Section 6 – Operational Test and Place in Service). When ready, install fuse following required steps (a – e) to ensure an IP67 connection. See Figure 5-48.
 - a. Insert new fuse.
 - b. Apply entire contents of supplied Dow Corning 4 (dielectric grease) inside inline fuse holder cover.
 - c. Snap cover in place and press firmly together around outer edges to properly seal.
 - d. Wipe off excess grease on outside of inline fuse holder.
 - e. May take up to a minute before green Power LED displays on the display module.

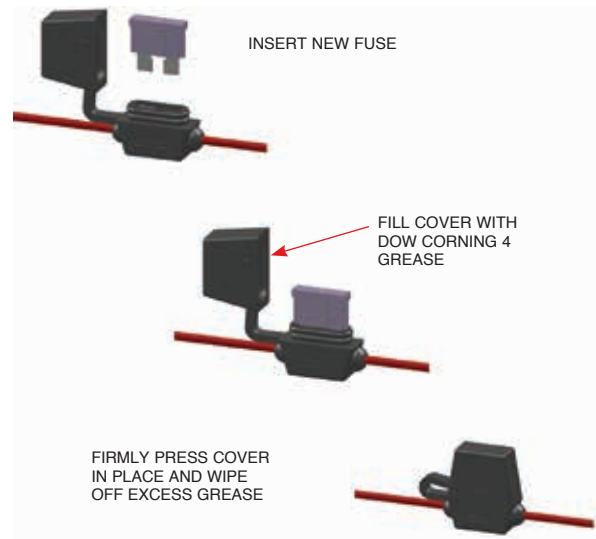

**FIGURE 5-48
 FUSE INSTALLATION**
 009228

POWER CIRCUIT CABLES (Continued)

NOTICE

Anytime fuse cover is opened or fuse is removed, review steps (a-e) to confirm fuse and cover are correctly replaced.

Cover must be completely refilled with Dow Corning #4 or equal (dielectric) grease before closing to maintain IP67 rating. Press cover firmly in place and wipe off excess grease.

► **DISCHARGE PRESSURE SWITCH**

The discharge pressure switch is a manually resettable SPDT switch. See Figure 5-49. The switch design specifically provides pressure switch feedback to the ICM through detection circuit #2.

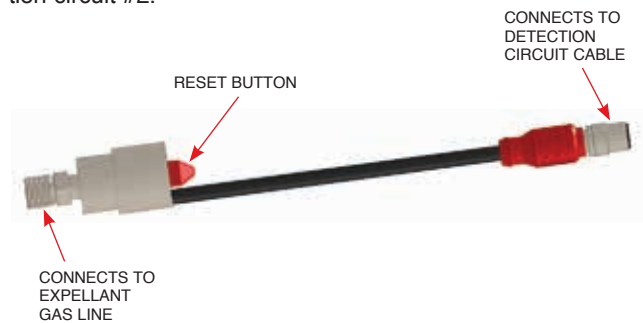

FIGURE 5-49
DISCHARGE PRESSURE SWITCH CONNECTIONS
009344

Standard installation of the pressure switch is at the agent tank (see Figure 5-50).

CAUTION

Locate pressure switch next to agent tank at end of expellant gas line. Failure to comply will cause pressure switch to not function properly.

1. Install pressure switch in expellant gas actuation line next to agent tank inlet port. Make certain to protect switch and connections from potential damage.
2. The switch installs in a standard 1/4 in. NPT female fitting. Insert the included 1/4 in. tee between expellant gas line hose from actuator and tank inlet port. Use Teflon tape on the male threads. See Figure 5-51 for proper wrench grip area.

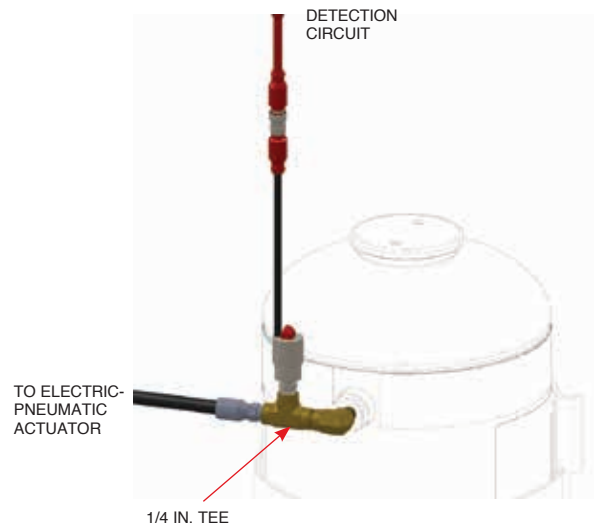

FIGURE 5-50
INSTALLED PRESSURE SWITCH
009345

CAUTION

When threading the switch into the expellant gas line tee, DO NOT apply torque directly to the metal switch body. Failure to comply may result in damage to the switch. Tighten ONLY by applying torque to the 1/4 in. NPT male pressure fitting. See Figure 5-51.

CAUTION

DO NOT install the pressure switch in the fire hazard area or in any area where the ambient temperature will exceed 175 °F (79 °C). Failure to comply may prevent the pressure switch from functioning properly.

► PRESSURE SWITCH ASSEMBLY (Continued)



FIGURE 5-51
WRENCH GRIP AREA
009231

Pressure Switch Reset

To reset the pressure switch, press the red reset button located on the back of the switch. An audible click should be heard. See Figure 4-49.

CAUTION

The discharge pressure switch must be manually reset **before** resetting the CHECKFIRE system. Failure to reset the switch could result in system activation.

System Connection

The discharge pressure switch includes a red color-coded connector for direct connection to Detection Circuit #2. Use a detection circuit tee to connect the switch on the branch line of the tee. Install an EOL Device to complete Detection Circuit #2. See Figure 5-52.

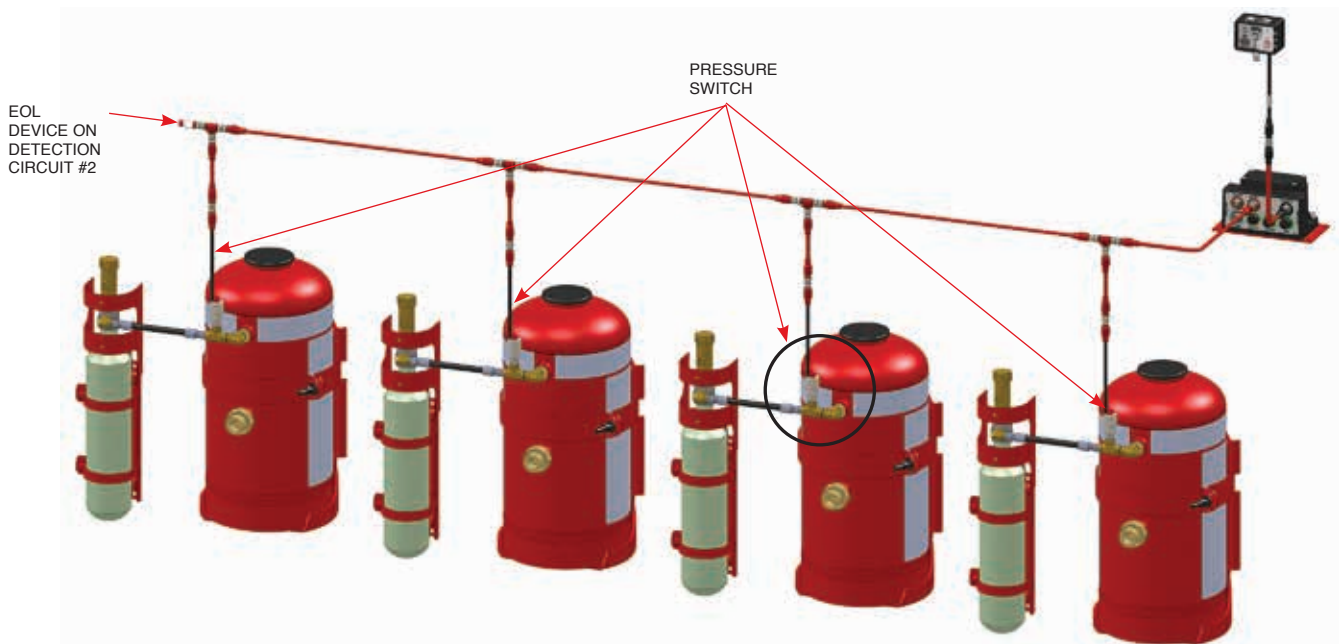

FIGURE 5-52
DETECTION CIRCUIT #2 CONNECTION
009352

LABEL PACKAGE
Part No. 440798

Provides reminders for equipment operators and service personnel on system operation and protection.

Attach appropriate labels as needed in the specified locations. See Figures 5-53 thru 5-56.

If automatic vehicle shutdown is part of the CHECKFIRE System, install Label No. 440799 near the operator's line of vision. Cut out the correct time delay value from Label No. 440800, remove backing to expose adhesive, and attach to Label 440799 in the space provided. See Figure 5-53.



FIGURE 5-53
LABEL FOR ENGINE SHUTDOWN AND TIME DELAY
 009174

If automatic vehicle shutdown is **NOT** part of the CHECKFIRE System, install Label No. 440801 near the operator's line of vision. See Figure 5-54.

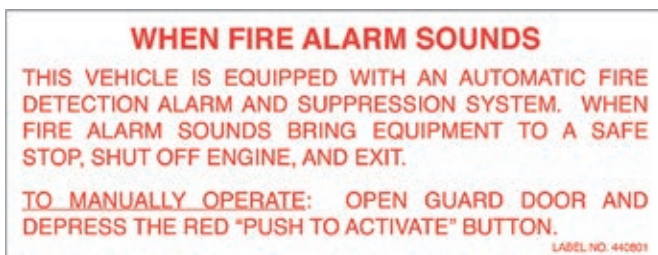

FIGURE 5-54
LABEL TO STOP VEHICLE AND EXIT
 009175

As a reminder to service and maintenance personnel, install this CAUTION (Label No. 441207) in the area protected by the Linear Detector. See Figure 5-55.

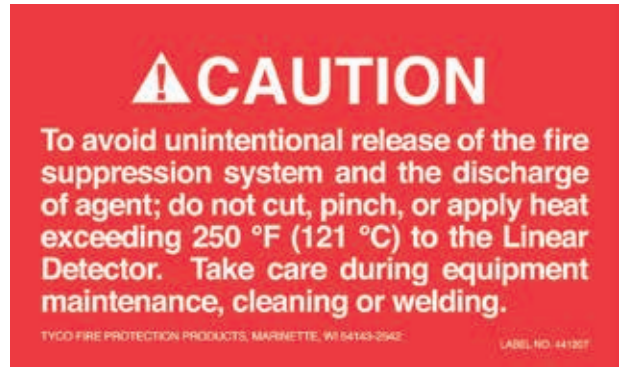

FIGURE 5-55
LABEL FOR PROTECTING LINEAR DETECTOR
 009325

Install Label No. 440802 next to every Electric Manual Actuator (EMA). See Figure 5-56.



FIGURE 5-56
INSTRUCTION LABEL FOR EMA
 009324

FINAL COMPONENT CONNECTIONS

Electric activation: Refer to Section 6 – Operational Test and Place in Service for final electric activation connections.

Combined electric and pneumatic actuation: Connect both pneumatic actuator hose(s) and Release Circuit Drop Cable(s) with installed PAD(s) (refer to electric actuation instructions in Section 6 – Operational Test and Place in Service).

PNEUMATIC MANUAL ACTUATION (Optional)

If layout drawing includes an optional pneumatic manual actuator in the operator's compartment, confirm the operator has access to the red strike button on the actuator. For detailed installation guidelines, refer to the appropriate system manual (latest edition).

LT-A-101-10/20/30 Manual	(Part No. 24327)
LT-A-101-50/125/250 Manual	(Part No. 427865)
LVS Manual	(Part No. 427109)

PROGRAMMING

The CHECKFIRE 210 System may be programmed manually or using a Personal Computer (PC). For manual programming with the ICM and Display Module (internal or external power required) use the Programming Button to turn programming LEDs on or off similar to dip switches (see Table 5-2 and 5-3). Instructions for manually saving the Event History Log are in Table 5-4.

If the display module or power is not available, the ICM can be programmed with a PC and the ANSUL CHECKFIRE 210 Programmer software (see Table 5-5). Programming system options and internal system information including a 4,000+ Event History Log are viewable on one screen.

A list of all circuits and a summary of programming options for each circuit are provided in Table 5-1.

TABLE 5-1: PROGRAMMING SUMMARY

LED Identifier(s)	Function Description	LED STATUS	
		LED OFF/Disabled (Default Function*)	LED ON/Enabled (Optional Function*)
PSF-1	Pressure Switch Feedback	No pressure switch feedback function	Pressure Switch Feedback – Pressure switch communicates to ICM through Detection Circuit #2 (for additional functionality see <i>Optional DET-4</i>). Note: Pressure Switch Feedback and Cross-Zone Detection can NOT operate together.
DET-2	Cross-Zone Detection	Det. Ckt. #1 and Det. Ckt. #2 operate as independent circuits	Cross-Zone Detection – Requires an alarm condition on both detection circuits #1 and #2 before starting Time Delay #1 (TD1).
DET-3	Detection Circuit #1	Independent detection/release	Alarm Only – Prohibits start of TD1 countdown for any alarm condition on Detection Circuit #1. (Not available when cross-zone detection, DET-2, is enabled.)
DET-4	Detection Circuit #2	Independent detection/release	Alarm Only – Prohibits start of TD1 countdown for any alarm condition on Detection Circuit #2. (Not available when cross-zone detection, DET-2, is enabled.)
DET-4 (Optional) (PSF-1 enabled)	<i>Pressure Switch Feedback - Enabled</i>	<i>System provides release notification, and sends release signal to PAD(s) (Optional = OFF)</i>	<i>System provides release notification, and does not send release signal to PAD(s). (Default = ON when Pressure Switch Feedback is enabled.)</i>
TD1-5 and TD1-6	Time Delay #1	10 second initial time delay period between an alarm condition and Time Delay #2 (TD2). Sec. TD1-5 TD1-6 10 OFF OFF Note: Cross-Zone requires alarm condition in both detection circuits before start of TD1.	Time Delay #1 (TD1) – Optional delay periods (0, 5 or 15 seconds) between an alarm condition and Time Delay #2 (TD2). Sec. TD1-5 TD1-6 0 ON ON 5 ON OFF 15 OFF ON
TD2-7 and TD2-8	Time Delay #2	10 second time delay period between Time Delay #1 (TD1) and system release. Sec. TD2-7 TD2-8 10 OFF OFF	Time Delay #2 (TD2) – Optional delay periods (0, 5 or 15 seconds) starting after Time Delay #1 (TD1). Sec. TD2-7 TD2-8 0 ON ON 5 ON OFF 15 OFF ON
TDR-9	Time Delay #1 (TD1) Restarts	2 Restarts	Unlimited restarts
RLY-10	Relay #1	Alarm – Relay contacts transfer on an alarm condition. Note: The relay returns to normal if the alarm condition clears.	Fault – Relay contacts transfer on any fault condition. Note: The relay returns to normal if the fault condition clears.
RLY-11	Relay #2	Shutdown: - Relay contacts transfer when TD1 expires. Note: Latching relay only transfers back to normal when system is reset from the Post Release Activated condition.	Alarm – Relay contacts transfer on an alarm condition. Note: The relay returns to normal if the alarm condition clears.

* When PSF-1 is enabled, DET-4 “ON” is the default and DET-4 “OFF” is optional.

Review the following tables with instructions on programming options for the CHECKFIRE 210 System.

TABLE 5-2: PREPARATION – ICM MANUAL PROGRAMMING MODE

Manual Programming With The ICM Programming Button (PB)

When using the Programming Button (PB), the ICM must be connected to the display module to save changes and powered with the internal battery or external power source. (Power LED on display module is steady-on or pulsing 1 x 3 seconds).

Programming steps are not saved until the display module is reset to Normal.

The programming button and programming LEDs are located under the ICM battery compartment cover.

The Programming LEDs function similar to mechanical dip switches and have two indications: ON (green) or OFF (not illuminated). The term “push” means to momentarily push and release the button. The phrase “press and hold” means to continue pressing the button down for the instructed length of time.

1. Loosen the four captive screws and remove cover to gain access to programming button and view LEDs.



2. Push programming button three times within one second (3 x 1) to place the CHECKFIRE 210 System in Programming Mode.

Programming LEDs remain steady-on for one second to indicate system is in programming mode, then PSF-1 pulses 1 x 1 second indicating it is currently selected. Remaining LEDs show ON or OFF programming status. (At initial power up, all LEDs are OFF indicating factory defaults.)

Note: When LED is selected, the “1 x 1 second” LED pulse will be twice as long per second when the LED is turned ON, than when the LED is turned OFF.

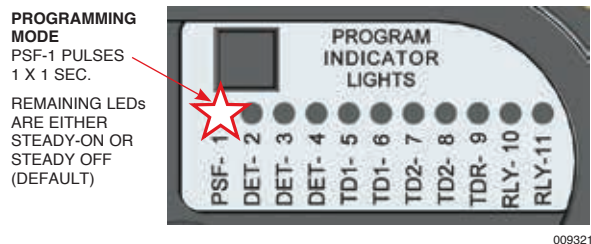
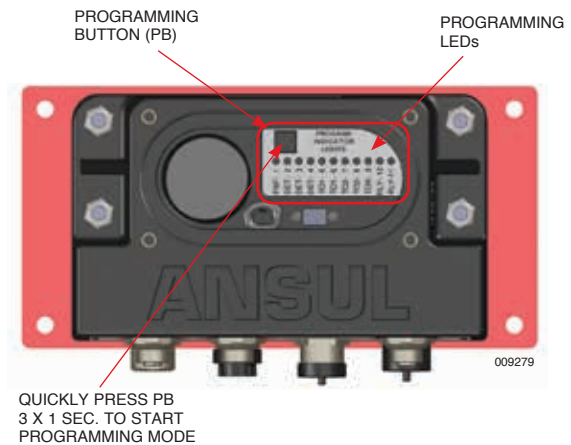

TABLE 5-2: PREPARATION – ICM MANUAL PROGRAMMING MODE (Continued)

- Push programming button once to advance to the next LED. The next LED pulses 1 x 1 second and previous LED is either ON or OFF showing programming status. Each programming button push advances through each of the LEDs.

PUSH PB ONCE TO ADVANCE TO NEXT LED



EACH PB PUSH ADVANCES TO NEXT LED



- While the selected LED is pulsing, **press and hold PB for longer than one second to change between ON or OFF status.** The pulse rate of the LED changes to indicate the change in status (twice as long for ON). Push programming button once to advance to the next LED and confirm ON/OFF status of previous LED.

PRESS AND HOLD PB TO CHANGE PULSING LED ON OR OFF



STEADY-ON

PULSING 1 X 1 SEC.

PUSH PB ONCE TO ADVANCE AND CONFIRM PREVIOUS LED CHANGED



- Complete a Reset to Normal to regularly save programming changes to the CHECKFIRE 210 System.
 Reset to Normal: Press and hold "DELAY/Reset/Silence" button for 3 seconds; Green and Red LEDs are steady-on for 1 second; then Amber LEDs are steady-on for 1 second; at end sounder quickly pulses 3 times.

SAVE PROGRAMMING:

RESET TO NORMAL

PRESS AND HOLD 3 SECONDS

LEDs TEST CYCLE THEN SOUNDER PULSES 3 TIMES



NOTICE

After 30 seconds of inactivity, Programming Mode automatically times out. Any modifications not saved to the System by a reset to normal on the Display Module will be lost.

TABLE 5-3: MANUAL PROGRAMMING OPTIONS

PSF-1, Pressure Switch Feedback

PSF-1 changes the function of Detection Circuit #2 between an independent detection/release circuit input (default programming – OFF) and pressure switch feedback input (ON).

1. If the system plan requires Pressure Switch Feedback functionality and PSF-1 is OFF, push programming button until PSF-1 is selected (pulsing at a rate of 1 x 1 second).
2. Press and hold the programming button for more than 1 second to turn ON the LED which specifies the function of Detection Circuit #2 (DET-4) for Pressure Switch Feedback input. The 1 x 1 second pulse of PSF-1 is now twice as long and DET-4 is steady-on.
3. Push the programming button to move to the next LED and confirm:
 - PSF-1 is steady-on
 - DET-2 is pulsing 1 x 1 second
 - DET-4 is steady-on
4. Save the ICM programming change.
 Reset to Normal: Press and hold “DELAY/Reset/Silence” button for 3 seconds; Green and Red LEDs are steady-on for 1 second; then Amber LEDs are steady-on for 1 second; at end sounder quickly pulses 3 times.

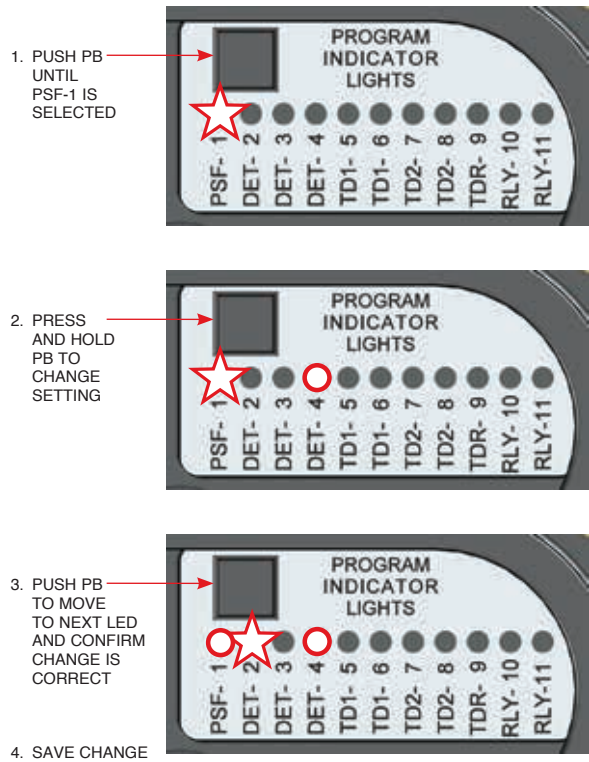

DET-2, Cross-Zone Detection

DET-2 changes between independent detection/release circuit operation for Detection Circuits #1 and #2 (default programming – OFF) and Cross-Zone detection (ON). Cross-Zone detection requires an alarm event on both Detection Circuits #1 and #2 before CHECKFIRE 210 System starts Time Delay #1 (TD1) for automatic release.

1. If the System plan requires Cross-Zone detection functionality, and DET-2 is OFF, push programming button until DET-2 is selected (pulsing at a rate of 1 x 1 second).
2. Press and hold the programming button for more than 1 second to turn ON the LED and enable the Cross-Zone function. The 1 x 1 second pulse is now twice as long.
3. Push the programming button to move to the next LED and confirm:
 - DET-2 is steady-on
 - DET-3 is pulsing 1 x 1 second
4. Save the ICM programming change.
 Reset to Normal: Press and hold “DELAY/Reset/Silence” button for 3 seconds; Green and Red LEDs are steady-on for 1 second; then Amber LEDs are steady-on for 1 second; at end sounder quickly pulses 3 times.

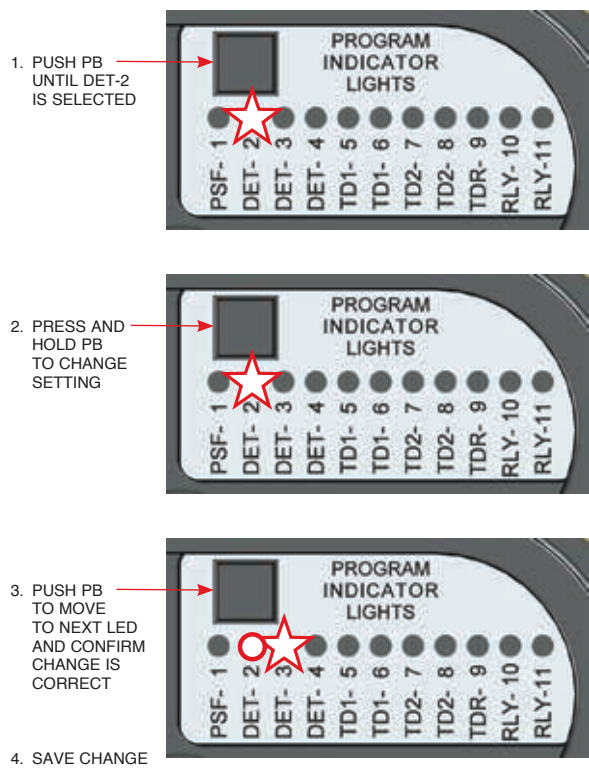

TABLE 5-3 – MANUAL PROGRAMMING OPTIONS (Continued)

**DET-3, Alarm Only, Detection Circuit #1
 (DET-2 must be OFF)**

DET-3 changes Detection Circuit #1 between independent detection/release operation (default programming – OFF) and Alarm Only functionality (ON).

The Alarm Only detection programming prohibits the CHECKFIRE 210 System from entering into automatic release countdown for any alarm condition detected by Detection Circuit #1. The System will continue to show alarm condition indefinitely, and will NOT activate the fire suppression system. [To initiate a manual discharge of the suppression system, push the “PUSH to Activate / Alarm When Lit” button on the display module or pull pin and strike a connected EMA. (Optional pneumatic operation may also be available.)]

Note: Alarm condition on Detection Circuit #2 will operate normally and provide an automatic activation, provided Detection Circuit #2 is NOT also programmed for Alarm Only operation.

1. If the system plan requires Alarm Only function for Detection Circuit #1 and DET-3 is OFF, push programming button until DET-3 is selected (pulsing at a rate of 1 x 1 second).

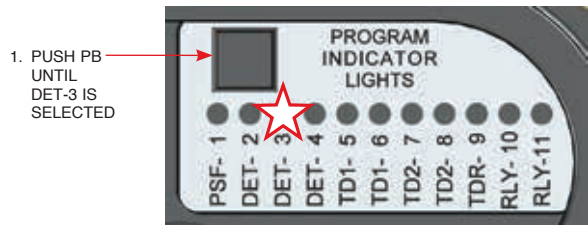

2. Press and hold the programming button for more than 1 second to turn ON the LED and specify the Alarm Only function. The 1 x 1 second pulse is now twice as long.
3. Push the programming button to move to the next LED and confirm:
 DET-3 is steady-on
 DET-4 is pulsing 1 x 1 second
4. Save the ICM programming change.
 Reset to Normal: Press and hold “DELAY/Reset/Silence” button for 3 seconds; Green and Red LEDs are steady-on for 1 second; then Amber LEDs are steady-on for 1 second; at end sounder quickly pulses 3 times.

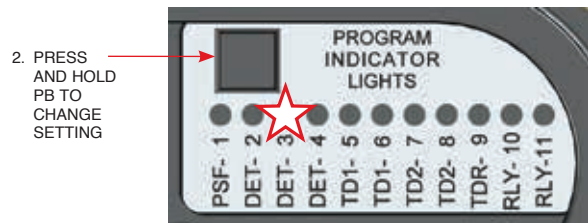

4. SAVE CHANGE

CAUTION

Programming both Detection Circuit #1 and Detection Circuit #2 for Alarm Only functionality will disable all automatic release functions of the CHECKFIRE 210 System. Manual actuation of the fire suppression system is required and failure to manually activate the system can result in significant property damage or personnel injury.

TABLE 5-3: MANUAL PROGRAMMING OPTIONS (Continued)

**DET-4, Alarm Only, Detection Circuit #2
 (PSF-1 and DET-2 must be OFF)**

DET-4 changes Detection Circuit #2 between independent detection/release operation (default programming – OFF) and Alarm Only functionality (ON).

The Alarm Only detection programming prohibits the CHECKFIRE 210 System from entering into an automatic release countdown for any alarm condition detected by Detection Circuit #2. The System will continue to show Alarm indication indefinitely, and will NOT activate the suppression system. [To initiate a manual discharge of the suppression system, push the “PUSH to Activate / Alarm When Lit” button on the display module or, pull pin and strike a connected EMA. (Optional pneumatic operation may also be available.)]

Note: Alarm condition on Detection Circuit #1 will operate normally and provide an automatic discharge, provided Detection Circuit #1 is NOT also programmed for Alarm Only operation.

1. If the system plan requires Alarm Only function for Detection Circuit #2 and DET-4 is OFF, push programming button until DET-4 is selected (pulsing at a rate of 1 x 1 second).



2. Press and hold the programming button for more than 1 second to turn ON the LED and specify the Alarm Only function. The 1 x 1 second pulse is now twice as long.
3. Push the programming button to move to the next LED and confirm:
 - DET-4 is steady-on
 - TD1-5 is pulsing 1 x 1 second
4. Save the ICM programming change.
 - Reset to Normal: Press and hold “DELAY/Reset/Silence” button for 3 seconds; Green and Red LEDs are steady-on for 1 second; then Amber LEDs are steady-on for 1 second; at end sounder quickly pulses 3 times.

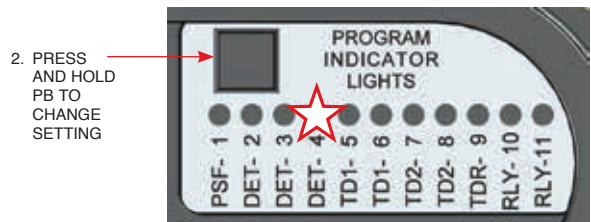

4. SAVE CHANGE

CAUTION

Programming both Detection Circuit #1 and Detection Circuit #2 for Alarm Only functionality will disable all automatic release functions of the CHECKFIRE 210 System. Manual actuation of the fire suppression system is required and failure to manually activate the system can result in significant property damage or personnel injury.

TABLE 5-3: MANUAL PROGRAMMING OPTIONS (Continued)

TD1-5 and TD1-6, Time Delay #1 (TD1) Programming

TD1 is the delay period between an alarm condition and TD2. TD1-5 and TD1-6 change Time Delay #1 (TD1) between the standard 10 seconds (default programming – TD1-5 OFF, and TD1-6 OFF) and 0, 5 or 15 seconds. Modifications made to TD1 do not affect the duration of Time Delay #2 (TD2).

1. Review system plan to determine value for TD1 (see below table for options). Push programming button as needed to select TD1-5 or TD1-6 to make appropriate adjustments to either LED.

Seconds	TD1-5	TD1-6
0	ON	ON
5	ON	OFF
10	OFF	OFF (default)
15	OFF	ON

2. Press and hold the programming button for more than 1 second to turn ON or OFF either LED to match the required time value.
3. Push the programming button to move to TD2-7 and confirm TD1-5 and TD1-6 are programmed correctly (see above table) and TD2-7 is pulsing 1 x 1 second.
4. Save the ICM programming change.
 Reset to Normal: Press and hold "DELAY/Reset/Silence" button for 3 seconds; Green and Red LEDs are steady-on for 1 second; then Amber LEDs are steady-on for 1 second; at end sounder quickly pulses 3 times.

CAUTION

TD1 is the delay period between an alarm condition and equipment shutdown. If using the shutdown relay function, programming TD1 to zero seconds results in immediate equipment shutdown and immediate start of TD2 upon initiation of an alarm condition.

CAUTION

Programming both Time Delay #1 and Time Delay #2 to zero seconds results in immediate System activation following an alarm condition. This situation could lead to immediate equipment shutdown (if using the shutdown relay function) or other unforeseen issues which could result in significant property damage or personal injury.

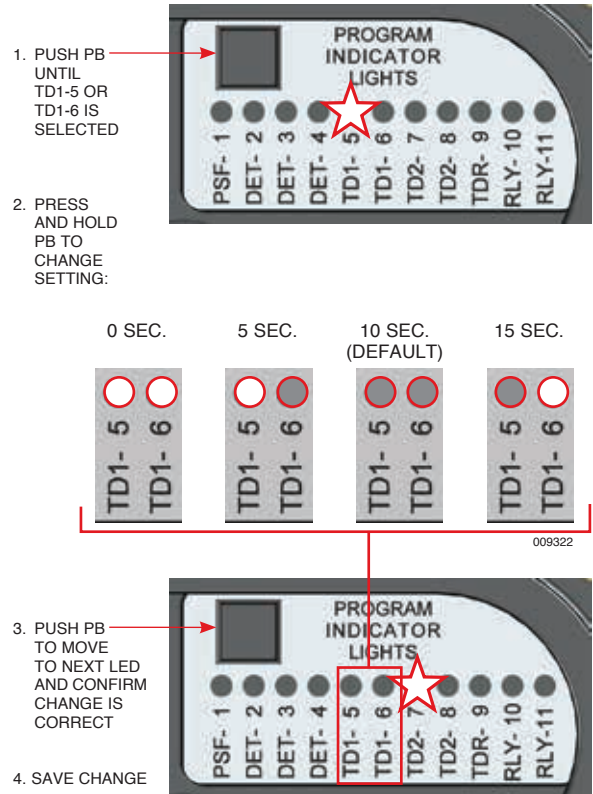

TABLE 5-3: MANUAL PROGRAMMING OPTIONS (Continued)

TD2-7 and TD2-8, Time Delay #2 (TD2) Programming

TD2 is the delay period between Time Delay #1 (TD1) and system release. TD2-7 and TD2-8 change Time Delay #2 (TD2) between the standard 10 seconds (default programming – TD2-7 OFF, and TD2-8 OFF) and 0, 5 or 15 seconds. Modifications made to TD2 do not affect the duration of Time Delay #1 (TD1).

1. Review system plan to determine value for TD2 (see below table for options). Push programming button as needed to select TD2-7 or TD2-8 to make appropriate adjustments to either LED.

Seconds	TD2-7	TD2-8
0	ON	ON
5	ON	OFF
10	OFF	OFF (default)
15	OFF	ON

2. Press and hold the programming button for more than 1 second to turn ON or OFF either LED to match the required time value.
3. Push the programming button to move to TDR-9 and confirm TD2-7 and TD2-8 are programmed correctly (see above table) and TDR-9 is pulsing 1 x 1 second.
4. Save the ICM programming change.
 Reset to Normal: Press and hold "DELAY/Reset/Silence" button for 3 seconds; Green and Red LEDs are steady-on for 1 second; then Amber LEDs are steady-on for 1 second; at end sounder quickly pulses 3 times.

CAUTION

TD2 is the delay period between TD1 and fire suppression release. If using the shutdown relay function, programming TD2 to zero seconds results in immediate fire suppression release at the same time as equipment shutdown.

CAUTION

Programming both Time Delay #1 and Time Delay #2 to zero seconds results in immediate System activation following an alarm condition. This situation could lead to immediate equipment shutdown (if using the shutdown relay function) or other unforeseen issues which could result in significant property damage or personal injury.

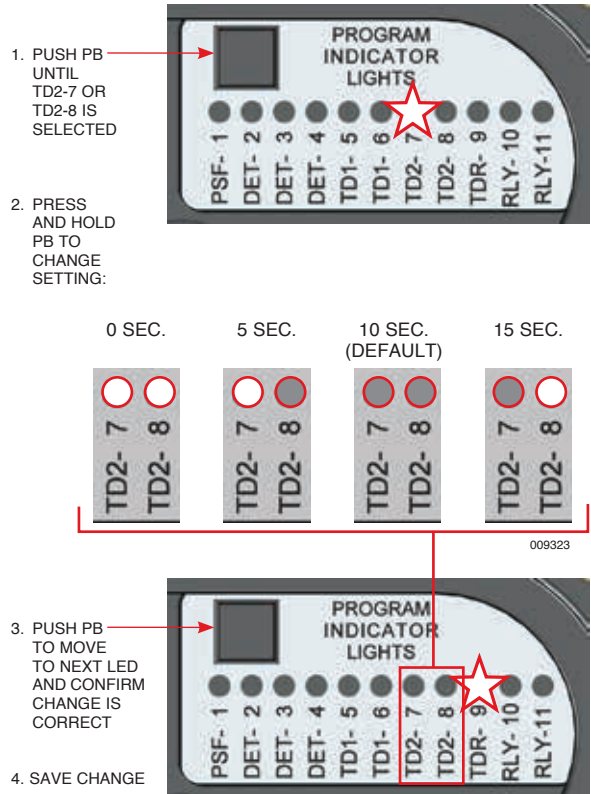

TABLE 5-3: MANUAL PROGRAMMING OPTIONS (Continued)

TDR-9, Time Delay Restarts for TD1

TDR-9 changes the number of times TD1 can be restarted from the display module between 2 restarts (default programming – OFF) and unlimited restarts (ON). TD1 is the time delay period between an alarm condition and TD2.

1. If the system plan requires unlimited restarts and TDR-9 is OFF, push programming button until TDR-9 is selected (pulsing at a rate of 1 x 1 second).

⚠ WARNING

Delay of system operation may allow the fire to intensify, which could result in a more difficult fire to suppress.

2. Press and hold the programming button for more than 1 second to turn ON TDR-9 and specify the unlimited restarts function. The 1 x 1 second pulse is now twice as long.
3. Push the programming button to move to the next LED and confirm
 - TDR-9 is steady-on
 - RLY-10 is pulsing 1 x 1 second.
4. Save the ICM programming change.
 Reset to Normal: Press and hold “DELAY/Reset/Silence” button for 3 seconds; Green and Red LEDs are steady-on for 1 second; then Amber LEDs are steady-on for 1 second; at end sounder quickly pulses 3 times.

1. PUSH PB UNTIL TDR-9 IS SELECTED

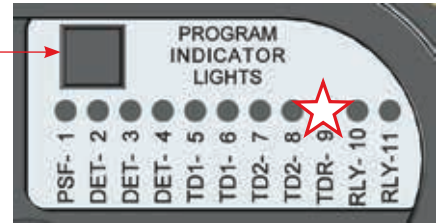

2. PRESS AND HOLD PB TO CHANGE SETTING

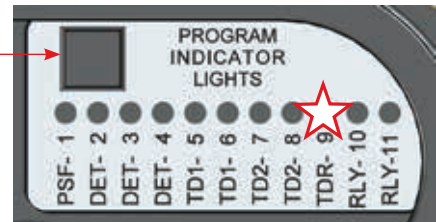

3. PUSH PB TO MOVE TO NEXT LED AND CONFIRM CHANGE IS CORRECT

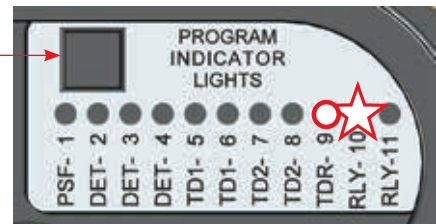

4. SAVE CHANGE

RLY-10, Relay #1, Alarm/Fault

RLY-10 changes the function of Internal Relay #1 between an Alarm relay (default – OFF) and a Fault relay (ON). Alarm functionality responds to an alarm condition. When programmed to the Fault functionality, a fault condition transfers the relay contacts. In both cases, the relay will return to normal once the alarm condition or fault clears.

1. If the system plan requires Relay #1 to function as a Fault relay and RLY-10 is OFF, push programming button until RLY-10 is selected (pulsing at a rate of 1 x 1 second).
2. Press and hold the programming button for more than 1 second to turn ON the LED and specify the Fault relay function. The 1 x 1 second pulse is now twice as long.
3. Push the programming button to move to the next LED and confirm
 - RLY-10 is steady-on
 - RLY-11 is pulsing 1 x 1 second.
4. Save the ICM programming change.
 Reset to Normal: Press and hold “DELAY/Reset/Silence” button for 3 seconds; Green and Red LEDs are steady-on for 1 second; then Amber LEDs are steady-on for 1 second; at end sounder quickly pulses 3 times.

1. PUSH PB UNTIL RLY-10 IS SELECTED

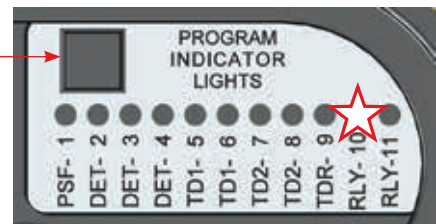

2. PRESS AND HOLD PB TO CHANGE SETTING

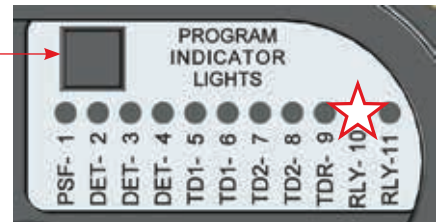

3. PUSH PB TO MOVE TO NEXT LED AND CONFIRM CHANGE IS CORRECT

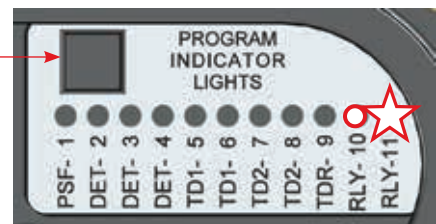

4. SAVE CHANGE

TABLE 5-3: MANUAL PROGRAMMING OPTIONS (Continued)

RLY-11, Relay #2, Shutdown/Alarm

RLY-11 changes the function of Internal Relay #2 between a Shutdown Relay (default programming – OFF) and an Alarm Relay (ON). When programmed to the Shutdown functionality the relay contacts transfer when TD1 expires. The latching relay will not transfer back to normal until the CHECKFIRE 210 System is reset from the Post Release Activated condition.

When programmed to the Alarm Relay functionality, the initiation of an alarm condition transfer the relay contacts. The relay will return to normal once the alarm condition clears.

1. If the system plan requires Relay #2 to function as an Alarm Relay and RLY-11 is OFF, push programming button until RLY-11 is selected (pulsing at a rate of 1 x 1 second).
2. Press and hold the programming button for more than 1 second to turn ON the LED and specify the Alarm Relay function. The 1 x 1 second pulse is now twice as long.
3. Push the programming button to move to the next LED and confirm
 - RLY-11 is steady-on
 - PSF-1 is pulsing 1 x 1 second.
4. Save the ICM programming change.
 Reset to Normal: Press and hold “DELAY/Reset/Silence” button for 3 seconds; Green and Red LEDs are steady-on for 1 second; then Amber LEDs are steady-on for 1 second; at end sounder quickly pulses 3 times.

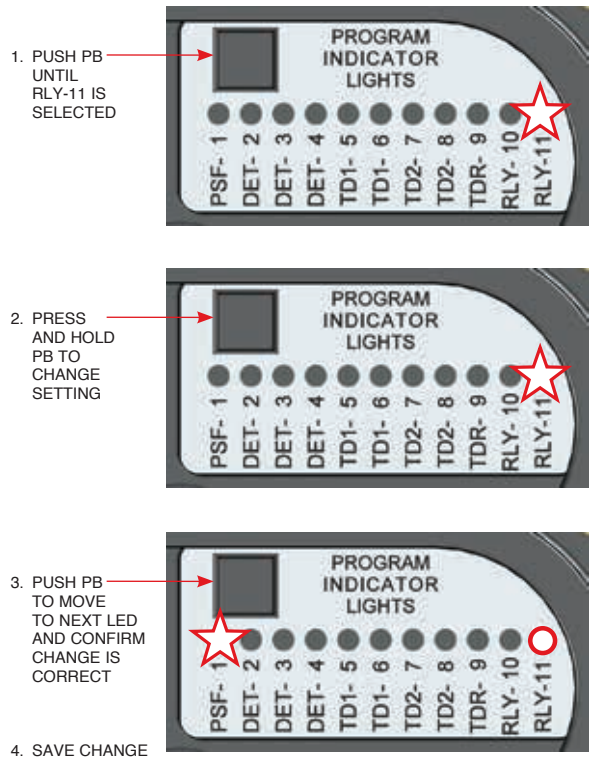

TABLE 5-4: DOWNLOAD EVENT HISTORY LOG

The Event History Log of the CHECKFIRE 210 System can be downloaded as a text file directly to a USB memory device (by others) without connection to a personal computer (PC). The USB memory device may then be plugged into a PC to print or save the file to a different location.

- Allows service personnel to retrieve programming and Event History Log without connecting a PC to ICM.
- Allows service personnel to save a text file which helps verify maintenance and operation of the CHECKFIRE 210 System.

Communication adapter cable (by others) is required to connect a standard USB memory device to the mini USB port on the ICM. Items needed:

1. Interface Cable: USB A Female receptacle and Mini A plug x 4 in. (102 mm) long
2. Standard USB memory device

TABLE 5-4: DOWNLOAD EVENT HISTORY LOG (Continued)

Accessing and Downloading the Event History Log

The Programming Button (PB) and programming LEDs are located under the ICM battery compartment cover. The programming button controls the download process and the programming LEDs indicate the start and end of the download.

Note: The Event History Log download should be performed at or near normal temperature conditions. Corrupted or incomplete history file data can occur if downloads are attempted at extreme high or low temperatures.

1. Loosen the (4) captive screws and remove cover to gain access to programming button and view LEDs.
 2. Connect the USB communication cable and memory device to the mini USB port near the programming LEDs.
 3. Push programming button 3 x 1 second to begin the file download. (ICM senses connection with a USB memory device and starts the download.)
 4. Programming LEDs pulse briefly to indicate system has initiated the download. Then all LEDs pulse in marquee fashion to indicate the ICM is writing the contents of the Event History Log to the USB memory device.
 5. When complete, all LEDs illuminate steady-on for 5 seconds. A text file is saved on the USB memory device with the current date. The text file name will be LOGxxx where the x place holders will be a number (e.g. 0001, 0002) determined by the last number of any previously saved text files on the USB memory device.
- Note:** The writing of the Event History Log can take several seconds to complete and **should not be interrupted**. If the writing is not successful after 30 seconds, the ICM will quickly pulse all LEDs together multiple times indicating an unsuccessful file download.
6. Disconnect cable and USB memory device. Re-install battery cover.

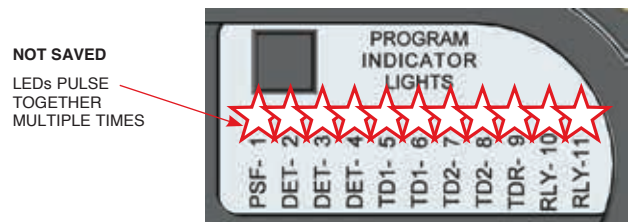
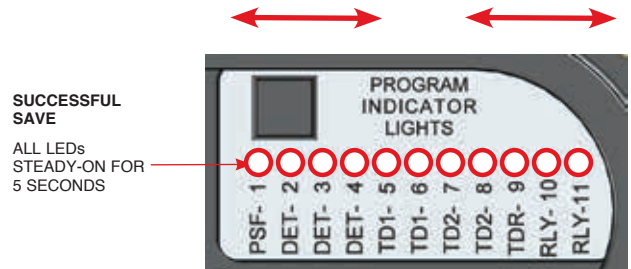
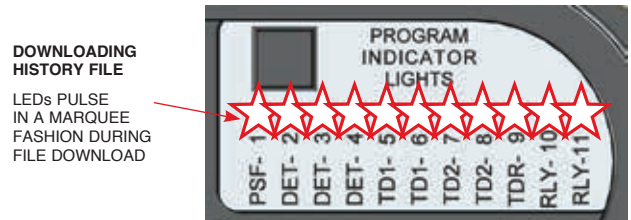
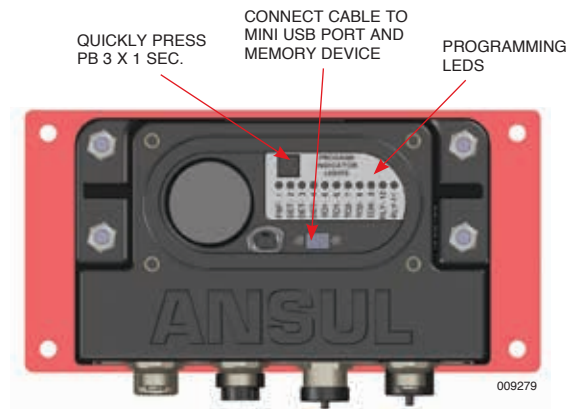

TABLE 5-5: PERSONAL COMPUTER (PC) OPTIONS

Personal Computer (PC) Programming

Authorized ANSUL Distributors with CHECKFIRE 210 System contracts have access to the ANSUL CHECKFIRE 210 Programmer software. The same programming options described in the previous table for the ICM have matching programming in the PC software.

Install the latest version of the ANSUL CHECKFIRE 210 Programmer utility software on a PC to read and write information to the ICM.

Note: It is not necessary to install a battery module or provide external power to the CHECKFIRE 210 ICM when using the PC interface. The PC provides power for system operation through the USB communication cable.

SAME PROGRAMMING OPTIONS AS THE ICM PROGRAMMING BUTTON AND LEDS

ICM PROGRAMMING LED IDENTIFIERS

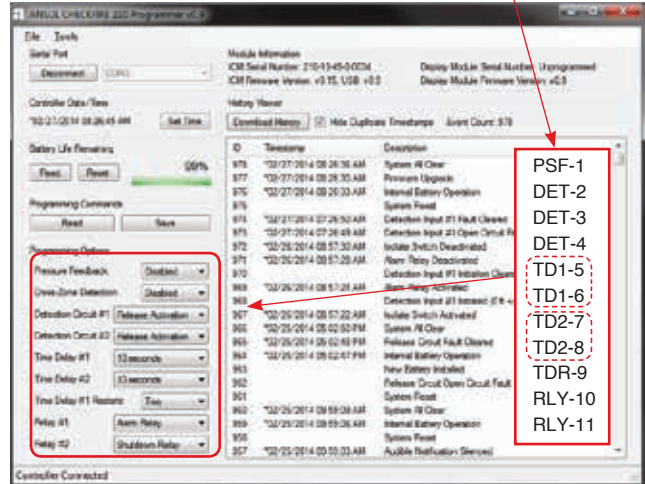

009326

Connecting the ICM to a PC

Establish communication between the ICM and a PC using the mini USB serial port under the ICM battery compartment cover.

- 1) Loosen the (4) captive screws and remove cover to gain access to the programming button.
- 2) Connect an appropriate USB Communication Cable* between the mini B USB port on the CHECKFIRE 210 ICM and a Standard A USB port on your PC.
 - * Interface Cable: USB A Male plug and Mini B plug x 10 ft (3 m) long.
- 3) Launch the CHECKFIRE 210 Programmer application software on the PC.
- 4) Select the appropriate COMM port from the drop down list at the top left of the application window then click Connect.

Note: PC programming should be performed at or near normal temperature conditions. Corrupted or incomplete data can occur if programming is attempted at extreme high or low temperatures.



009279

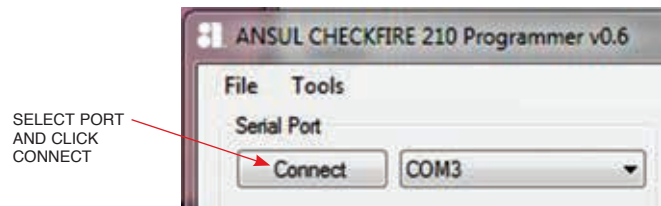

009327

TABLE 5-5: PERSONAL COMPUTER (PC) OPTIONS (Continued)

Reading System Information	SERIAL NUMBER AND FIRMWARE VERSIONS
<p>With proper communications established the software automatically populates system information, including serial numbers, firmware versions, and current programming.</p>	
<p>At initial System startup, all programming options are programmed to factory defaults.</p>	009328
<p>Note: If display module is not connected to the ICM, the display module information is shown as “No response.”</p>	
Programming The System Clock	
<p>The internal real-time clock, default programmed to Greenwich Mean Time (GMT), can be programmed to the date and time on the PC (typically local time). In the Controller Date/Time section click the Set Time button to synchronize the ICM clock with the PC date and time. The system clock can be updated multiple times as required.</p>	
<p>Note: Programming the date/time does not affect the history file.</p>	SYNCHRONIZES ICM CLOCK WITH PC CLOCK
	009329

TABLE 5-5: PERSONAL COMPUTER (PC) OPTIONS (Continued)

Battery Life Remaining

The ICM monitors the expected lifetime of the internal battery. Click the Read button under Battery Life Remaining section to view remaining battery life percentage.

When only using internal power, battery must be replaced annually, after a discharge or when low power is indicated.

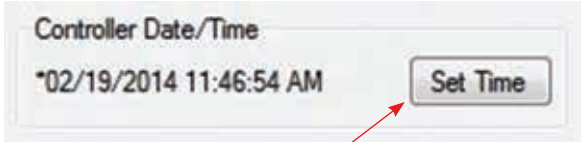
When using dual power, internal battery must be replaced when there is a low power indication or battery life remaining is less than 25%.

Only click the Reset button for installation of a new/unused battery module. When clicked, the battery life indicator resets to full.

Note: When replacing the battery module (e. g., during annual maintenance) the battery life indicator can be reset from the ICM without connecting to a PC. (Section 8 – Recharge, Inspection, and Maintenance also has the following instructions.)

- 1) Replace the battery module with a new/unused unit. Record the replacement date on the inside sticker of the battery compartment cover and on the battery itself.
- 2) Place the CHECKFIRE 210 System into Isolate Mode using the isolate switch on the side of the ICM.
- 3) Press and hold the Programming Button for more than five (5) seconds then release.
- 4) All programming LEDs pulse 3 x 1 second to confirm battery life indicator is reset.
- 5) Cancel Isolate Mode by returning the isolate switch to the normal position.

CAUTION

Performing a reset of the battery life indicator without installing a new/unused replacement battery module can result in faulty battery indications and unpredictable CHECKFIRE 210 System operation.

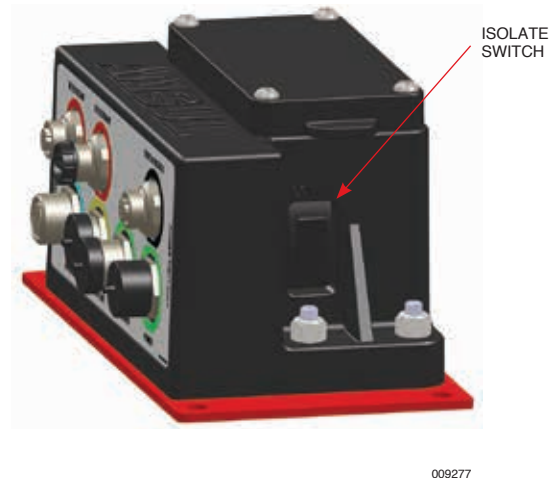
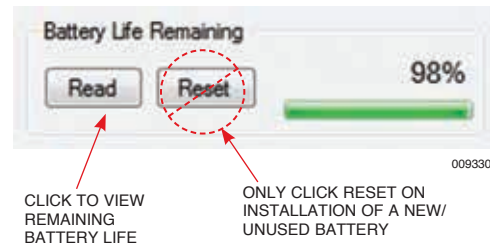

Programming Commands

The Read button in the Programming Commands section uploads the current ICM programming for the CHECKFIRE 210 System. When making changes to the programming, click the Save button to save the change to the ICM.



TABLE 5-5: PERSONAL COMPUTER (PC) OPTIONS (Continued)

Modifying Programming Options

Each of the options shown in Table 5-1 – Programming Summary (page 5-22) is programmed using a drop down menu and clicking the desired options. Certain options will be grayed out when others are selected. When options turn red, the programming has not been saved to the ICM.

Default Programming

Circuit Option (ICM LED Identifier)	Function
1. Pressure Feedback (PSF-1)	Disabled
2. Cross-Zone Detection (DET-2)	Disabled
3. Detection Circuit #1 (DET-3)	Release Act.
4. Detection Circuit #2 (DET-4)	Release Act.
5. Time Delay #1 (TD1-5 and TD1-6)	10 sec. delay
6. Time Delay #2 (TD2-7 and TD2-8)	10 sec. delay
7. Time Delay #1 Restarts (TDR-9)	Two restarts
8. Relay #1 (RLY-10)	Alarm
9. Relay #2 (RLY-11)	Shutdown

Alternate Programming:

- Pressure Switch Feedback – Pressure switch communicates to ICM through Detection Circuit #2.
- Cross-Zone Detection – Requires an alarm condition on both Detection Circuits #1 and #2 before starting Time Delay #1 (TD1).
- Det. Ckt. #1 - Alarm Only – Prohibits start of TD1 count-down for any alarm condition on Detection Circuit #1. (Not available when cross-zone detection is enabled.)
- Det. Ckt. #2 - Alarm Only – Prohibits start of TD1 count-down for any alarm condition on Detection Circuit #2. (Not available when cross-zone detection is enabled.)
 - Alarm Only - System provides release notification, and does not send release signal to PAD(s) (Default when Pressure Switch Feedback is enabled)*
 - Release Activation - System provides release notification, and sends release signal to PAD(s) (Optional when Pressure Switch Feedback is enabled)*
- Time Delay #1 (TD1) – Optional delay periods (0, 5 or 15 seconds) between an alarm condition and Time Delay #2 (TD2).
- Time Delay #2 (TD2) – Optional delay periods (0, 5 or 15 seconds) starting after time delay #1 (TD1).
- Time Delay #1 Restarts - Unlimited restarts.
- Relay #1 - Fault – Relay contacts transfer on any fault condition.
- Relay #2 - Alarm – Relay contacts transfer on an alarm condition.

FACTORY
 DEFAULT
 SETTINGS

009332

RED
 HIGHLIGHTING
 INDICATES
 PROGRAMMING
 NOT SAVED
 TO ICM

GREYED OUT
 DROP DOWN
 INDICATES
 OPTION NOT
 AVAILABLE

009333

TABLE 5-5: PERSONAL COMPUTER (PC) OPTIONS (Continued)

History Viewer

The History Viewer section displays upto 4,096 events in the Event History Log and automatically uploads all events when changes are made.

Each event record includes a timestamp with real date and time. When multiple events share the same timestamp duplicate timestamps can be hidden by selecting the Hide Duplicate Timestamps checkbox. Events occurring at the same time are listed underneath a single timestamp.

See Section 8 – Recharge, Inspection and Maintenance for a list of Event History Log messages.

To save the Event History Log as a text file select Save from the drop down list under File on the Menu Bar.

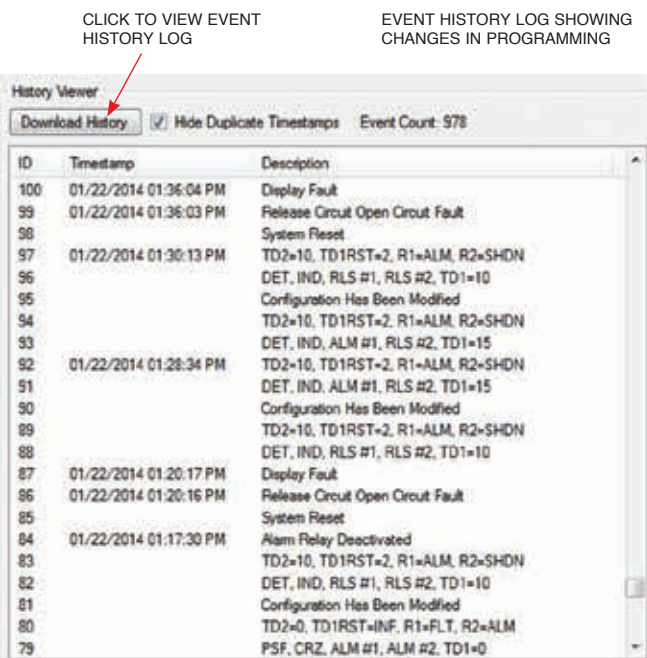

009334

EVENT HISTORY LOG SHOWING ACTIVATION MESSAGES

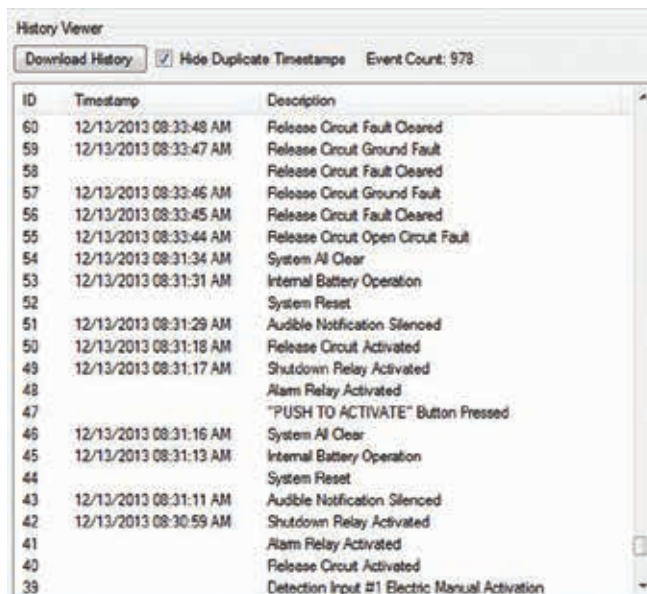

009335

EVENT HISTORY LOG - PROGRAMMING

The Checkfire 210 System records changes made to System Programming in the Event History Log. Each programming change is indicated with the message “Configuration Has Been Modified.” The message includes the programming before and after modification. Two lines of lower ID sequential numbers before the message list the previous configuration; two lines of higher ID sequential numbers after the message report the modified configuration. Refer to Table 5-6 – Event History Log Programming Descriptions to identify the acronyms representing programming options.

1011	*02/27/2014 08:47:02 AM	TD2=10, TD1RST=2, R1=ALM, R2=SHDN	AFTER SAVING MODIFICATIONS
1010		DET, IND, ALM #1, RLS #2, TD1=15	
1009		Configuration Has Been Modified	BEFORE SAVING MODIFICATIONS
1008		TD2=10, TD1RST=2, R1=ALM, R2=SHDN	
1007		DET, IND, RLS #1, RLS #2, TD1=10	

For Example: In the sample Event History Log shown above, the System was modified on February 27, 2014 at 8:47 AM. Two changes were made: Detection Circuit #1 was re-programmed to Alarm Only, and Time Delay #1 was re-programmed from a 10 second delay (default) to a 15 second delay. Remaining programming options were unchanged.

Table 5-6 – Event History Log Programming Descriptions

Position	Default	Optional Programming	Description
1	DET	PSF	DET Detection Circuit #2 programmed as a detection circuit PSF Programmed for Pressure Switch Feedback.
2	IND	CRZ	IND Detection Circuits #1 & #2 programmed as detection circuits CRZ Programmed for Cross-Zone Detection
3	RLS #1	ALM #1	RLS #1 Detection Circuit #1 programmed for independent detection/release ALM #1 Detection Circuit #1 programmed for Alarm Only indication
4	RLS #2	ALM #2	RLS #2 Detection Circuit #2 programmed for independent detection/release ALM #2 Detection Circuit #2 programmed for Alarm Only indication
5	TD1=10	TD1= (0,5,15)	TD1=10 Time Delay #1 programmed for 10 seconds (default) TD1= xx TD1 programmed for 0, 5, or 15 seconds.
6	TD2=10	TD2= (0,5,15)	TD2=10 Time Delay #2 programmed for 10 seconds (default) TD2= xx TD2 programmed for 0, 5, or 15 seconds.
7	TD1RST=2	TD1RST=INF	TD1RST=2 Time Delay #1 programmed for two restarts TD1RST=INF Time Delay #1 programmed for infinite restarts
8	R1=ALM	R1=FLT	R1=ALM Relay #1 programmed for Alarm relay R1=FLT Relay #1 programmed for Fault relay ()
9	R2=SHDN	R2=ALM	R2=SHDN Relay #2 programmed for Shutdown relay R2=ALM Relay #2 programmed for Alarm relay

NOTES:

CAUTION

Before performing any operational test(s), protect the fire suppression system from unintentional actuation. Verify Electric-Pneumatic Actuators are not connected to Release Circuit Drop Cables and any pneumatic manual actuators are ring-pinned for safety and/or actuation cartridges removed.

The following tables are step-by-step instructions to complete testing and place the system in service. If unexpected results occur refer to Section 9 – Troubleshooting section.

TABLE 6-1: PREPARATION – OPERATIONAL TEST

Release Circuit	
<div style="background-color: yellow; text-align: center; padding: 5px;">⚠ CAUTION</div> <p>When handling the PAD, always point actuating end away from yourself and others. On electrical initiation, PAD operates very quickly and a small brass disk forcefully separates from actuating end. Physical injury may occur from contact with the actuating pin and/or the detaching disk.</p> <hr/> <p>Before conducting the OPERATIONAL TEST, confirm all installed Release Circuit Drop Cables have a Release Circuit Tester (RCT) (Part No. 441021) and/or a Release Circuit Test Plug (Part No. 440912) installed.</p> <ol style="list-style-type: none"> 1. Insert Release Circuit Test Plug in socket of Release Circuit Drop Cable(s). (If installed remove PAD.) 2. On last Release Circuit Drop Cable insert RCT. (If installed remove PAD.) <p>Switch on top of RCT must be turned on for testing. LEDs on front indicate status: Ready, Pass, Fail, and replace RCT battery.</p> <p>After RCT indicates pass or fail, press switch on top to reset the tester.</p> <p>Note: If there is a single Electric-Pneumatic Actuator, connect RCT to Release Circuit Drop Cable. Release Circuit Test Plug is not installed.</p>	<div style="text-align: center;">  <p>IF INSTALLED, REMOVE PAD(S)</p> </div> <div style="text-align: center; margin-top: 10px;"> <p>IF USING TWO OR MORE DROP CABLES, INSTALL RELEASE CIRCUIT TEST PLUG IN DROPPED SECTION OF CABLE(S)</p>  <p>INSERT RCT INTO LAST RELEASE CIRCUIT DROP CABLE</p> <p>INSERT RELEASE CIRCUIT TEST PLUG IN DROPPED SECTION(S) OF CIRCUIT</p> </div>
<div style="background-color: yellow; text-align: center; padding: 5px;">CAUTION</div> <p>When performing any operational test(s), make certain RCT and Release Circuit Test Plug(s), as required, are attached to the release circuit.</p>	

TABLE 6-1: PREPARATION – OPERATIONAL TEST (Continued)

Detection Circuit #1 (and #2)

Before conducting OPERATIONAL TEST, install the Detection Circuit Tester (DCT) (Part No. 440097).

1. Remove the Detection Circuit EOL Device from detection circuit.
2. Set DCT to "Normal" condition then install DCT.

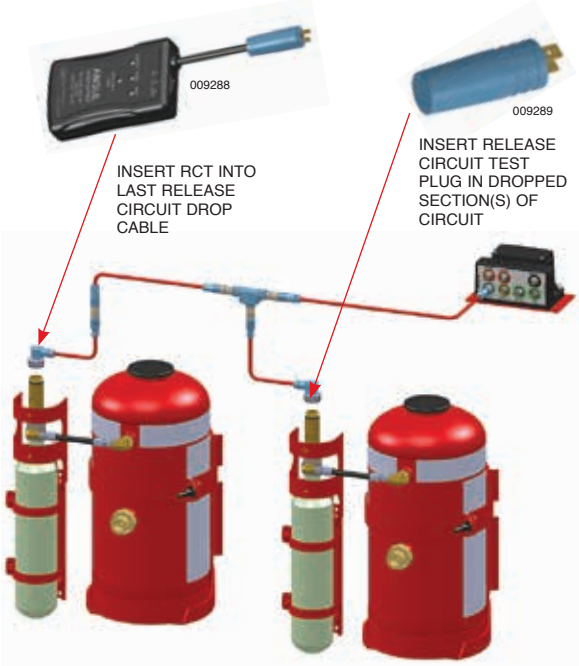
REMOVE DETECTION
CIRCUIT EOL DEVICE



SET DCT TO
"NORMAL"
AND INSTALL

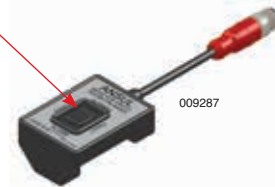

Power Up (External or dual power only)

Before conducting the OPERATIONAL TEST, make certain external power is properly connected to CHECKFIRE 210 System (see Section 5 – Installation and Programming, page 5-17).

- If 3 amp fuse is not installed for external power, follow instructions in Section 5 – Installation and Programming, page 5-17 (step 5).

CONFIRM
CONNECTIONS

INLINE FUSE
HOLDER

RED TO POSITIVE (+)
BATTERY POST



**FOLLOW SECTION 5 – INSTALLATION
INSTRUCTIONS TO INSTALL FUSE**

BLACK TO NEGATIVE (-)
BATTERY POST

- If using dual power install battery

1. Remove battery compartment cover.
2. Insert battery into battery well; align connector keyways and connect battery pigtail with battery cable on the ICM.

BATTERY
PIGTAIL

BATTERY CABLE



TABLE 6-1: PREPARATION – OPERATIONAL TEST (Continued)







Power Up (External or dual power only) (Continued)

- Reset to Normal: Press and hold “DELAY/Reset/Silence” button for 3 seconds; Green and Red LEDs are steady-on for 1 second; then Amber LEDs are steady-on for 1 second; at end sounder quickly pulses 3 times.
- Power LED is Green steady-on for External or Dual Power

NOTICE

Confirm no other LEDs are pulsing. If fault or alarm conditions are indicated, refer to Section 9 – Troubleshooting to clear all conditions prior to performing the operational test.

KEY TO DISPLAY MODULE INDICATIONS – IDENTIFY LEDs AS:

					
LED STEADY-ON (Red or Green)		LED PULSING (Amber, Red or Green)			LED OFF

RESET TO NORMAL
 PRESS AND HOLD 3 SECONDS
 LEDs TEST CYCLE THEN SOUNDER PULSES 3 TIMES
 LED IS GREEN STEADY-ON



009290

Power Up (Internal power only)

Before conducting the OPERATIONAL TEST, make certain internal power is properly connected to CHECKFIRE 210 System.

- Install battery:
 1. Remove battery compartment cover.
 2. Insert battery into battery well; align connector keyways and connect battery pigtail with battery cable on the ICM.
- Reset to Normal: Press and hold “DELAY/Reset/Silence” button for 3 seconds; Green and Red LEDs are steady-on for 1 second; then Amber LEDs are steady-on for 1 second; at end sounder quickly pulses 3 times.
- Power LED pulses Green 1 x 3 seconds for Internal Power



009347

Note: For system running on Internal power only, refer to Table 6-4: Internal Power Circuit Only – Operational Test, for specific testing procedures.

NOTICE

Confirm no other LEDs are pulsing. If fault or alarm conditions are indicated, refer to Section 9 – Troubleshooting to clear all conditions prior to performing the operational test.

RESET TO NORMAL
 PRESS AND HOLD 3 SECONDS
 LEDs TEST CYCLE THEN SOUNDER PULSES 3 TIMES
 GREEN LED PULSES 1 X 3 SECONDS



009290

TABLE 6-2: ISOLATION FEATURE (External or Dual Power Only)

The CHECKFIRE 210 System includes an Isolation Feature for equipment service personnel to help minimize the possibility of a false fire suppression system discharge when service or maintenance takes place on the protected vehicle/equipment (not intended for CHECKFIRE 210 System maintenance).

⚠ CAUTION

When placed in Isolate Mode, the Release Circuit cannot be initiated by an automatic detection circuit input.

In the event of fire, manual actuation bypasses Isolate Mode. To operate manually:

- Press “PUSH to Activate/ Alarm When Lit” button
- Or**
- Pull ring pin and operate RED Strike button on an EMA or a pneumatic manual actuator

Place the CHECKFIRE 210 System in Isolate Mode then confirm: system will not auto release and will manually actuate while in Isolate Mode.

Note: While in Isolate Mode, service personnel can perform service and maintenance on the equipment as needed.

1. Put system in Isolate Mode using the Isolate switch on the side of the ICM.



2. The Amber Isolate LED and sounder on the Display Module will quickly pulse 2 x 30 seconds.
3. If desired, push the “DELAY/Reset/Silence” button to silence the sounder.

ISOLATE MODE
 AMBER LED AND
 SOUNDER PULSE
 2 X 30 SECONDS



TABLE 6-2: ISOLATION FEATURE (External or Dual Power Only) (Continued)

- Set DCT switch to “Alarm” position. Confirm Red Detection 1 LED, Red “Push to Activate / Alarm When Lit” LED and sounder pulse 1 x 1 second; Amber Isolate LED and sounder pulse 2 x 30 seconds.

Verify time delays do not start.

**ALARM CONDITION
 DCT = ALARM**

 RED/AMBER LEDs
 AND SOUNDER
 PULSE
 1 X 1 SECOND,
 AMBER LED PULSES
 2 X 30 SECONDS

 VERIFY TIME
 DELAYS
 DO NOT START



- After 30 seconds of indication, open the protective guard door and push the “PUSH to Activate / Alarm When Lit” button. Release Activated starts immediately.

Note: There is no time delay upon manual activation.

- Release Activated** – The Red “PUSH to Activate / Alarm When Lit” LED, Red Shutdown LED, Red Detection 1 LED, and sounder are steady-on for 10 seconds; Amber Isolate LED pulses 2 x 30 seconds.

**RELEASE
 ACTIVATED**

 RED LEDs AND
 SOUNDER
 STEADY-ON FOR 10
 SECONDS, AMBER
 LED PULSES
 2 X 30 SECONDS



- Post Release Activated** – The Red Shutdown LED, Red Detection 1 LED, and sounder pulse 1 x 10 seconds; and Amber Isolate LED and sounder pulse 2 x 30 seconds.

**POST RELEASE
 ACTIVATED**

 RED LEDs AND
 SOUNDER PULSE
 1 X 1 SECOND,
 AMBER LED PULSES
 2 X 30 SECONDS



- Push the “DELAY/Reset/Silence” button to test sounder silence. Sounder silences and LEDs continue.

PUSH BUTTON

SOUNDER STOPS



TABLE 6-2: ISOLATION FEATURE (External or Dual Power Only) (Continued)

9. Confirm successful release signal (Pass) on RCT.
10. Reset DCT to “Normal” position.
11. Reset RCT.
12. Cancel Isolate Mode by returning the Isolate switch to the normal position.
13. Reset to Normal: Press and hold “DELAY/Reset/Silence” button for 3 seconds; Green and Red LEDs are steady-on for 1 second; then Amber LEDs are steady-on for 1 second; at end sounder quickly pulses 3 times.



TABLE 6-3: OPERATIONAL TEST

The following tests verify system operation for:

1. Circuit Supervision: Confirm supervisory function of each circuit.
2. Detection Circuit Input: Receive electrical signal from a detection device on #1 and #2 detection circuits (simulated fire condition).
3. Time Delay: Verify accuracy of time delay programming.
4. Spot Thermal Detectors: Verify contact closure.
5. Electric Manual Activation: Receive electrical signal from an EMA.

If noted results are not attained, refer to Section 9 – Troubleshooting for corrective action.

NOTICE

If the system is connected to a vehicle/equipment shutdown device through the pressure switch, verification needs to be made at the pressure switch.

NOTICE

During testing, verify any devices connected to Relay #1 and Relay #2 function as intended.

CAUTION

Before performing any operational test(s), protect the fire suppression system from unintentional actuation. Verify Electric-Pneumatic Actuators are not connected to Release Circuit Drop Cables and any pneumatic manual actuators are ring-pinned for safety and/or actuation cartridges removed.

CAUTION

When performing any operational testing, make certain the RCT (Part No. 441021) and Release Circuit Test Plug(s) (Part No. 440912) are attached to the release circuit.

TABLE 6-3: OPERATIONAL TEST (Continued)

Detection Circuit #1 (and #2) - Supervision Test

Confirm DCT is in place of the EOL Device on Detection Circuit #1. Set DCT switch to “Fault” position. The CHECKFIRE 210 Display Module indicates the following:

1. Amber Detection 1 LED and sounder pulse 1 x 10 seconds.
2. If fault relay is programmed, confirm activation of connected devices.
3. Push the “DELAY/Reset/Silence” button to test sounder silence. Sounder silences and LED continues.

**DETECTION 1
 FAULT INDICATION
 (DCT = FAULT)**

AMBER LED AND
 SOUNDER PULSE
 1 X 10 SECONDS



009290

PUSH BUTTON

SOUNDER STOPS



4. Reset the DCT to the “Normal” position.
5. CHECKFIRE 210 Display Module returns to normal status; Power LED is GREEN steady-on.

**RESET DCT TO
 NORMAL**

MODULE
 RETURNS TO
 NORMAL STATUS

POWER LED IS
 GREEN STEADY-ON



009290

Release Circuit - Supervision Test

Remove RCT from the Release Circuit. The CHECKFIRE 210 Display Module indicates the following.

1. Amber Release LED and sounder pulse 1 x 10 seconds.
2. Push the “DELAY/Reset/Silence” button to test sounder silence. Sounder silences and LED continues.

**RELEASE
 FAULT INDICATION
 (RCT REMOVED)**

AMBER LED AND
 SOUNDER PULSE
 1 X 10 SECONDS



009290

PUSH BUTTON

SOUNDER STOPS



3. Reconnect RCT to release circuit.
4. CHECKFIRE 210 Display Module returns to normal status; Power LED is GREEN steady-on.

RECONNECT RCT

MODULE
 RETURNS TO
 NORMAL STATUS

POWER LED IS
 GREEN STEADY-ON



009290

TABLE 6-3: OPERATIONAL TEST (Continued)

External Power Circuit – Supervision Test (Dual Power)

Disconnect the external power circuit connection at the CHECKFIRE 210 ICM Power Circuit receptacle.

1. Power LED pulses AMBER 1 x 3 seconds.
2. Reset to Normal: Press and hold “DELAY/Reset/Silence” button for 3 seconds; Green and Red LEDs are steady-on for 1 second; then Amber LEDs are steady-on for 1 second; at end sounder quickly pulses 3 times.

After reset, Power LED pulses GREEN 1 x 3 seconds confirming external power loss and operation on internal power.

POWER SUPERVISION (REMOVE POWER CABLE)

AMBER LED PULSES 1 X 3 SECONDS



009290

POWER SUPERVISION AFTER RESET WITHOUT EXTERNAL POWER

GREEN LED PULSES 1 X 3 SECONDS



009290

3. Reconnect external power circuit at the ICM. The CHECKFIRE 210 Display Module Power LED is GREEN steady-on.

RECONNECT EXTERNAL POWER

SYSTEM RETURNS TO NORMAL STATUS

POWER LED IS GREEN STEADY-ON



009290

TABLE 6-3: OPERATIONAL TEST (Continued)

Detection Circuit #1 (and #2): Alarm Condition Test

CAUTION

Before beginning this test, verify:

- Release Circuit Test Plug(s) and RCT are connected in the Release Circuit.
- DCT replaces the EOL Device in Detection Circuit #1.
- Determine the delay periods of TD1 and TD2 from the programming options.

1. Simulate alarm condition by turning switch on DCT to "Alarm" position.
2. If alarm relay is programmed, confirm activation of connected devices.
3. Verify accuracy of time delay:
 - a. The Red "PUSH to Activate / Alarm When Lit" LED, the Red Detection 1 LED, and sounder pulse two times per second until last 5 seconds of the TD1 period.

 In the last 5 seconds of TD1, the Red LEDs listed above, Red Shutdown LED, and sounder pulse 4 x 1 second for 4 seconds, then only the Red Shutdown LED is steady-on for the last second.
 - b. During TD2 period the pulse rate continues at 4 x 1 second.
4. Release Circuit Activation: Upon expiration of both TD1 and TD2 time delays, the Release Circuit activates.

CAUTION
 VERIFY RCT AND
 DCT INSTALLED!

**START OF
 DETECTION CIRCUIT
 ALARM CONDITION
 (DCT = ALARM)**

RED LEDs AND
 SOUNDER PULSE
 2 X 1 SECOND UNTIL
 LAST 5 SECONDS
 OF TD1 PULSE 4 X 1
 SECOND.



009290

5 SECONDS BEFORE
 TD1 END,
 RED LEDs AND
 SOUNDER PULSE
 4 X 1 SECOND FOR
 4 SECONDS
 THEN STEADY-ON FOR
 LAST SECOND.

DURING TD2 RED
 LEDs AND SOUNDER
 PULSE 4 X 1 SECOND.



009290

ONLY SHUTDOWN
 LED IS
 STEADY-ON FOR
 LAST SECOND
 OF TD1.



009290

DURING TD2 RED LEDs
 AND SOUNDER PULSE
 4 X 1 SECOND.



009290

TABLE 6-3: OPERATIONAL TEST (Continued)

Detection Circuit #1 (and #2): Alarm Condition Test (Continued)

5. **Release Activated:** The Red “PUSH to Activate / Alarm When Lit” LED, Red Detection 1 LED, Red Shutdown LED, and sounder remain steady-on for 10 seconds.

RELEASE ACTIVATED

RED LEDs AND SOUNDER REMAIN STEADY-ON FOR 10 SECONDS



6. **Post Release Activated:** The Red Detection 1 LED, Red Shutdown LED, and sounder pulse 1 x 10 seconds.

7. Push the “DELAY/Reset/Silence” button to test sounder silence. Sounder silences and LEDs continue.

8. Confirm RCT displays “PASS.”

POST RELEASE ACTIVATED

RED LEDs AND SOUNDER PULSE 1 X 10 SECONDS



PUSH BUTTON

SOUNDER STOPS

CONFIRM RCT DISPLAYS “PASS”



Detection Circuit #1 (and #2): Test Time Delay Restart

1. Reset DCT to “Normal” position.

2. Reset RCT - press reset button.

3. Reset to Normal: Press and hold “DELAY/Reset/Silence” button for 3 seconds; Green and Red LEDs are steady-on for 1 second; then Amber LEDs are steady-on for 1 second; at end sounder quickly pulses 3 times.

After reset, Power LED remains GREEN steady-on.

RETURN TO NORMAL STATUS

RESET DCT, RCT, AND DISPLAY MODULE

POWER LED IS GREEN STEADY-ON



009290

TABLE 6-3: OPERATIONAL TEST (Continued)

Detection Circuit #1 (and #2): Test Time Delay Restart (Continued)

4. Initiate alarm condition by turning DCT switch to "Alarm."
5. Before the TD1 time delay period expires, push "DELAY/Reset/Silence" button to restart time delay (3 quick pulses indicate time is restarted). Time delay #1 restarts to full programmed delay period. (Restarts may be limited to 2 restarts or repeated indefinitely based on optional programming.)

Note: Holding button down does not pause the time delay.

Note: During TD2 time delay cannot be restarted.

6. Allow System to complete time delay cycles (TD1 and TD2). During Release Activated* (LEDs and sounder steady-on) push the "DELAY/Reset/Silence" button. Verify:
 - a. Time delay will not restart.
 - b. Sounder will not silence.

* Red "PUSH to Activate / Alarm When Lit" LED, Red Shutdown LED, Red Detection 1 LED, and sounder remain steady-on for 10 seconds.

7. Confirm successful release signal (Pass) on RCT.

**TEST TIME DELAY
 DCT = ALARM**

BEFORE END OF TD1, PUSH BUTTON TO RESTART TD1 (MAY PUSH BUTTON MULTIPLE TIMES IF ALLOWED)

3 PULSES INDICATE RESTART



009290

COMPLETE TIME DELAYS

PUSH BUTTON DURING RELEASE ACTIVATED (RED LEDs AND SOUNDER STEADY-ON)

– VERIFY NO RESPONSE TO PUSHING BUTTON

CONFIRM RCT DISPLAYS "PASS"



009290

8. Return to normal:
 - a. Reset DCT to normal position.
 - b. Reset RCT - press reset button.
 - c. Reset to Normal: Press and hold "DELAY/Reset/Silence" button for 3 seconds; Green and Red LEDs are steady-on for 1 second; then Amber LEDs are steady-on for 1 second; at end sounder quickly pulses 3 times.

After reset, Power LED remains GREEN steady-on.

9. If Detection Circuit #2 is part of the system, repeat Detection Circuit Tests (listed below) using Detection Circuit #2 in place of Detection Circuit #1. Confirm DCT is in place of the EOL device on Detection Circuit #2. All figures with Detection 1 LED indicators will be Detection 2 LED indicators.

Detection Circuit Supervision Test, page 6-7

Detection Circuit Alarm Condition Test, page 6-9

Detection Circuit Test Time Delay Restart, page 6-10

RETURN TO NORMAL STATUS

RESET DCT, RCT, AND DISPLAY MODULE

POWER LED IS GREEN STEADY-ON



009290

TABLE 6-3: OPERATIONAL TEST (Continued)

Field Test Spot Thermal Detectors

This field test procedure is not intended to determine the exact operating temperature of any detector. It is designed to test functionality only.

To properly perform the following test procedure, the following materials will be required:

- Programmable heat gun
- Appropriate source of AC power (or converters)
- Appropriate safety gear (safety glasses, heat resistant hand protection, etc.)



CAUTION

Do NOT apply any direct flame or other unregulated heat sources to the detector head as this could damage the temperature-sensing element. Damage to the temperature-sensing element in the detector head will result in system impairment.

CAUTION

This test procedure requires the use of test equipment that can develop hazardous temperatures capable of causing injury to personnel. Persons conducting the testing must read and follow all safety rules that are included in the Operating Manual for the particular heat gun being used prior to beginning this test procedure.

CAUTION

This test procedure requires personnel to work around potential hazardous temperatures and voltages. Ensure all equipment, around the detectors to be tested, is de-energized and properly locked-out prior to beginning this test procedure.

TABLE 6-3: OPERATIONAL TEST (Continued)

Field Test Spot Thermal Detectors (Continued)

To test the functionality of the Spot Thermal Detector:

1. Put system in Isolate Mode using the Isolate switch on the side of the ICM.
Confirm Isolate LED and sounder pulse 2 x 30 seconds.
2. Ensure the heat gun is properly connected per the manufacturer's recommendations and turn it on. The applied temperature for the 250 °F (121 °C) detector should not exceed 400 °F (204 °C), and the applied temperature for the 350 °F (176.6 °C) detector should not exceed 500 °F (260 °C).

3. Position the tip of the heat gun as close to the detector head as possible and begin applying heat to the unit. The direction of the applied heat should be as perpendicular to the face of the detector head as possible. See Figure 8-6.
4. Continue to apply heat to the detector head until contact closure occurs. An audible click should be heard from the detector head and the System should go into alarm (LEDs and sounder pulse 1 x 1 second). **Note:** Reaction times between detectors will vary. Air movement in the vicinity of the detectors should be minimized to the greatest extent possible. Excessive air movement will affect heat transfer to the detector which may extend activation times.
5. As soon as contact closure occurs, immediately and carefully remove the tip of the heat gun from the detector head. **Note:** Detector will remain in alarm for several seconds before contacts re-open.
6. Allow the detector head to cool enough for the contacts to re-open. Verify the alarm condition clears.
7. Repeat Steps 2 – 6 for each detector that requires testing.
8. Once all detectors have been tested and contacts are re-opened (see step 6), the detection system should be returned to normal operation. Cancel Isolate mode by returning the Isolate switch to the normal position.

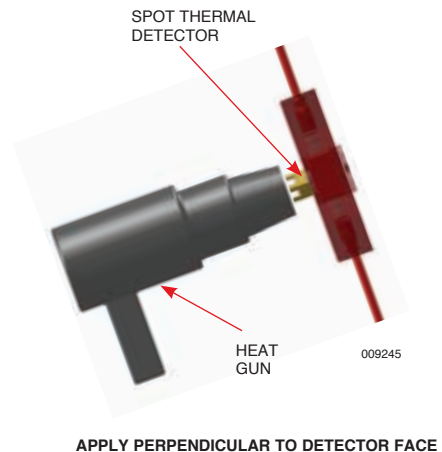

TABLE 6-3: OPERATIONAL TEST (Continued)

Manual Activation Release Circuit Test
 – including programmable equipment shutdown

If system is utilizing the equipment shutdown feature through the internal relay, the following steps confirm the proper operation of the shutdown. These steps will require operation of equipment.

Note: If needed, contact appropriate personnel for authorization of equipment start up and testing.

1. Start up equipment.
2. Open the protective guard door and push the “PUSH to Activate / Alarm When Lit” button. Release Activated starts immediately.

Confirm successful equipment shutdown.

Note: There is no time delay upon manual activation.

3. **Release Activated** – The Red “PUSH to Activate / Alarm When Lit” LED, Red Shutdown LED, and sounder are steady-on for 10 seconds.

START EQUIPMENT
 OPEN DOOR
 PUSH RED BUTTON

RELEASE ACTIVATED

RED LEDs AND SOUNDER REMAIN STEADY-ON FOR 10 SECONDS



009343

4. **Post Release Activated** – The Red Shutdown LED, and sounder pulse 1 x 10 seconds.
5. Push the “DELAY/Reset/Silence” button to test sounder silence. Sounder silences and LEDs continue.
6. Confirm successful release signal (Pass) on RCT.

POST RELEASE ACTIVATED CONTINUES UNTIL MODULE IS RESET

RED LEDs AND SOUNDER PULSE 1 X 10 SECONDS

PUSH BUTTON

SOUNDER STOPS

CONFIRM RCT DISPLAYS “PASS”



009290

7. Reset RCT.
8. Reset to Normal: Press and hold “DELAY/Reset/Silence” button for 3 seconds; Green and Red LEDs are steady-on for 1 second; then Amber LEDs are steady-on for 1 second; at end sounder quickly pulses 3 times. After reset, Power LED remains GREEN steady-on.

RETURN TO NORMAL STATUS

RESET RCT AND DISPLAY MODULE

POWER LED IS GREEN STEADY-ON



009290

TABLE 6-3: OPERATIONAL TEST (Continued)

Electric Manual Actuator (EMA) Test

CAUTION

If the system includes Pneumatic Manual Actuator(s), test these components separately in accordance with the appropriate system manual (latest edition):

LT-A-101-10/20/30 Manual (Part No. 24327)

LT-A-101-50/125/250 Manual (Part No. 427865)

LVS Manual (Part No. 427109)

The actuators also have ring pins and red strike buttons. Actuation can cause fire suppression system release.

1. Pull ring pin and strike red button to manually operate EMA.

Note: There is no time delay upon manual activation.

2. **Release Activated** – The Red “PUSH to Activate / Alarm When Lit” LED, Red Shutdown LED, Red Detection 1 (or Detection 2) LED and sounder are steady-on for 10 seconds.

3. **Post Release Activated** – The Red Detection 1 (or Detection 2) LED, Red Shutdown LED, and sounder pulse 1 x 10 seconds.

4. Confirm successful release signal (Pass) on RCT.

PULL RING PIN AND STRIKE RED BUTTON



RELEASE ACTIVATED

RED LEDs AND SOUNDER REMAIN STEADY-ON FOR 10 SECONDS

NOTE: DETECTION 2 LED WILL PULSE WHEN EMA IS INSTALLED ON DETECTION CIRCUIT #2



POST RELEASE ACTIVATED

CONTINUES UNTIL MODULE IS RESET

RED LEDs AND SOUNDER PULSE 1 X 10 SECONDS



TABLE 6-3: OPERATIONAL TEST (Continued)

Electric Manual Actuator (EMA) Test (Continued)

5. Reset EMA by pulling red strike button up to set position, re-install ring pin. Do not reseal at this time.
6. Reset RCT.
7. Reset to Normal: Press and hold “DELAY/Reset/Silence” button for 3 seconds; Green and Red LEDs are steady-on for 1 second; then Amber LEDs are steady-on for 1 second; at end sounder quickly pulses 3 times.
8. Repeat Test for each remaining EMA following above steps.

CAUTION

If the system includes Pneumatic Manual Actuator(s), test these components separately in accordance with the appropriate system manual (latest edition):

LT-A-101-10/20/30 Manual (Part No. 24327)

LT-A-101-50/125/250 Manual (Part No. 427865)

LVS Manual (Part No. 427109)

The actuators also have ring pins and red strike buttons. Actuation can cause fire suppression system release.

RESET EMA:
PULL RED BUTTON UP,
INSERT RING PIN



RETURN TO
NORMAL STATUS

RESET RCT, AND
MODULE

POWER LED IS
GREEN STEADY-ON



TABLE 6-4: INTERNAL POWER ONLY – OPERATIONAL TEST

Systems Using Internal Power Only

1. Power LED pulses GREEN 1 x 3 seconds.
2. Complete the following tests (pages 6-9 thru 6-16) with system on internal power:
 - Detection Circuit: Alarm Condition Test
 - Detection Circuit: Test Time Delay Restart
 - Field Test Spot Thermal Detectors
 - Manual Activation Release Circuit Test
 - Electric Manual Actuator (EMA) Test

Note: For above tests the Power LED continues to pulse GREEN 1 x 3 seconds.

Note: If battery is low, Power LED pulses Amber 1 x 10 seconds.

INTERNAL POWER TESTING

GREEN LED PULSES
1 X 3 SECONDS

REPEAT TESTS
PAGES 6-8 –6-15 ON
INTERNAL POWER



009290

TABLE 6-6: PLACING CHECKFIRE 210 SYSTEM IN SERVICE

1. Disconnect all power. Disconnect external power circuit connection at the CHECKFIRE 210 ICM Power receptacle. If internal battery is installed, disconnect ICM battery cable from battery pigtail.

DISCONNECT ALL POWER



009290

2. Confirm all EMAs are in the up / ring-pinned positions and properly re-sealed with a visual seal.

ALL EMAs IN UP/PINNED POSITION AND SEALED



009153

3. Close guard door for “PUSH To Activate / Alarm When Lit” button and install visual seal.



009275

SEAL GUARD DOOR PROTECTING RED BUTTON

4. Replace DCT(s) with Detection EOL Device(s) in the detection circuit(s).

REPLACE DCT WITH EOL DEVICE IN DETECTION CIRCUIT(S)



009161

5. Remove RCT and/or Release Circuit Test Plug(s) from Release Circuit Drop Cable(s).

REMOVE RCT AND RELEASE CIRCUIT TEST PLUG(S)



009239

TABLE 6-6: PLACING CHECKFIRE 210 SYSTEM IN SERVICE (Continued)

6. Remove actuator cap on top of Electric-Pneumatic Actuator and retain for future use.

CAUTION

When handling the PAD, always point actuating end away from yourself and others. On electrical initiation, PAD operates very quickly and a small brass disk forcefully separates from actuating end. Physical injury may occur from contact with the actuating pin and/or the detaching disk.

7. Put system in Isolate Mode using the Isolate switch on the side of the ICM.

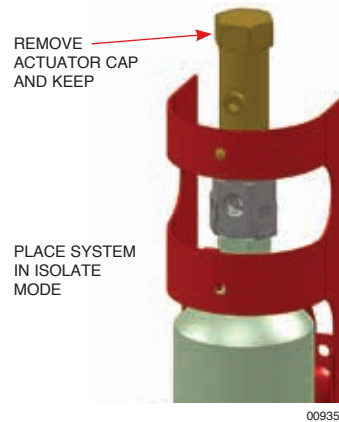

8. Write installation date on PAD, DO NOT cover manufacturing date on label. Install PAD into Release Circuit Drop Cable. Verify o-ring is in place on PAD.

NOTICE

The PAD (must be replaced after being in-service for five years.

- a. The in-service date should be recorded in installation and maintenance records and written on the PAD label with permanent marker at the time of installation.
- b. The PAD has a 10 year shelf life when stored in an environmentally stable location. The 5 year in-service life may not extend beyond the 10 year shelf life. (The month and year of manufacture is printed on the label located on the PAD body).

WRITE INSTALL DATE ON PAD LABEL
 MAKE SURE MANUFACTURING DATE IS READABLE



PAD FIELD INSTALLED IN CABLE

Install all PADs in the Release Circuit Drop Cable(s).

9. Attach Release Circuit Drop Cable to Electric-Pneumatic Actuator, hand-tighten connector. (Keep actuator cap for recharge and maintenance procedures.)

CAUTION

FOR ELECTRIC ACTUATION ONLY 1/4 IN. BRASS PLUGS MUST REMAIN IN PLACE OR FIRE SUPPRESSION SYSTEM WILL NOT OPERATE.

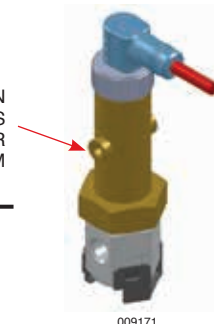



TABLE 6-6: PLACING CHECKFIRE 210 SYSTEM IN SERVICE (Continued)

<p>10. If needed complete installation of optional pneumatic manual actuator(s). Refer to Section 5 – Installation and Programming.</p> <p>11. Re-install pneumatic manual actuator cartridge(s) if previously removed.</p> <p>12. Reconnect all power as required. Reconnect external power circuit connection at the CHECKFIRE 210 ICM Power receptacle. If internal battery is required, reconnect ICM battery cable to battery pigtail.</p> <p>13. Confirm system is clear of faults and alarm conditions.</p> <p>14. Cancel Isolate mode by returning the Isolate switch to the normal position.</p>	<p>ELECTRONIC ACTIVATION INSTALLATION COMPLETE</p> <p>IF REMOVED, RE-INSTALL MANUAL ACTUATOR CARTRIDGE(S)</p> <p>RECONNECT ALL POWER</p> <p>CONFIRM SYSTEM CLEAR OF FAULTS AND/OR ALARM CONDITIONS</p> <p>REMOVE SYSTEM FROM ISOLATE MODE</p>	 <p>009171</p>
<p>15. Reset to Normal: Press and hold “DELAY/Reset/Silence” button for 3 seconds; Green and Red LEDs are steady-on for 1 second; then Amber LEDs are steady-on for 1 second; at end sounder quickly pulses 3 times.</p> <p>16. Record results of testing. If desired, download Event History Log, refer to Section 5 – Installation and Programming, page 5-33 (manual) or 5-38 (PC). When complete re-install battery cover.</p>	<p>RESET TO NORMAL</p> <p>PRESS AND HOLD 3 SECONDS</p> <p>POWER LED IS GREEN STEADY-ON</p>	 <p>009290</p>

NOTES:

IN CASE OF FIRE

Read these instructions and precautions carefully until they are clearly understood. All equipment operators or anyone who has any responsibility for the equipment should understand how to operate the CHECKFIRE 210 Detection and Actuation System. Every operator should be completely trained in these procedures.

- When the detection circuit alarm sounds, bring the equipment to a safe controlled stop, shut off the engine, and exit.
Note: Equipment left running may add fuel to the fire or reignite the fire with heat or sparks.
- If possible, safely exit and move a safe distance from equipment, and stand by with hand portable extinguisher

⚠ WARNING

In case of fire, evacuate area to lessen risk of injury from flames, heat, hazardous vapors, explosions, or other hazards.

Automatic Detection and System Actuation

The CHECKFIRE 210 Detection and Actuation System includes a thermal detection device(s) located in each protected area. On detecting an alarm condition, the CHECKFIRE 210 System starts the time delay cycle; at the end of the cycle an electrical release signal initiates the fire suppression system.

Manual System Operation

Bring equipment to a safe stop, shut off engine, and manually actuate system.

Perform one of the following to manually operate the system:

- Open guard door on CHECKFIRE 210 Display Module (break visual seal), and push the “PUSH To Activate / Alarm When Lit” button, see Figure 7-1.
- Pull ring pin and strike red strike button on an Electric Manual Actuator (EMA), see Figure 7-1.
- If an optional pneumatic actuation system is installed, pull ring pin and strike red button on the pneumatic manual actuator.

Safely exit and move a safe distance from equipment, and stand by with hand portable extinguisher.

⚠ CAUTION

Manual system operation will result in immediate system discharge which may obscure vision. Make certain equipment is stopped safely before manually operating system.

Automatic Equipment Shutdown

The CHECKFIRE 210 System includes programmable relays that may be connected to a shutdown device. If a shutdown device is connected to a CHECKFIRE 210 relay, make certain all responsible personnel understand shutdown device operation, and when it will operate with reference to a release/discharge condition.

If the “DELAY/Reset/Silence” button (on the display module) is pushed and released **before the end of Time Delay #1 (TD1)** (5, 10 or 15 seconds), the time delay restarts the time delay period. This will delay transfer of the shutdown relay and the start of Time Delay #2 (TD2) (0, 5, 10 or 15 seconds), and eventual system activation. This delay can be repeated (using the “DELAY/Reset/Silence” button) if necessary, to safely stop the equipment before the shutdown relay transfers automatically shutting down the equipment and activating the system.

Note: Press and hold will not pause the time delay.

⚠ WARNING

Delay of system operation may allow the fire to intensify, which could result in a more difficult fire to suppress.

Exit Vehicle/Equipment and Move Safely Away

Bring equipment to a safe controlled stop as soon as possible.

If fire suppression system has not yet operated, manually operate system (refer to Manual System Operation in this section).

Exit the vehicle/equipment (with hand portable fire extinguisher), and move away from the equipment. Stand by with hand portable fire extinguisher to guard against any fire that may reignite after fire suppression system has been discharged. Remain alert until equipment cools and possibility of re-ignition is no longer a threat.

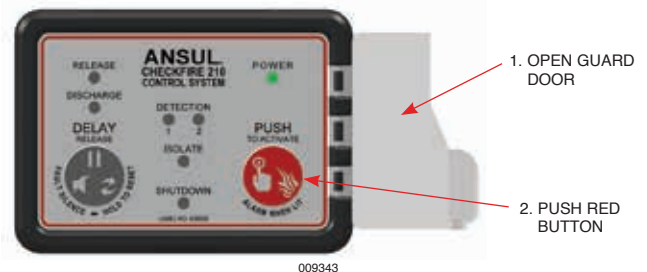

OR

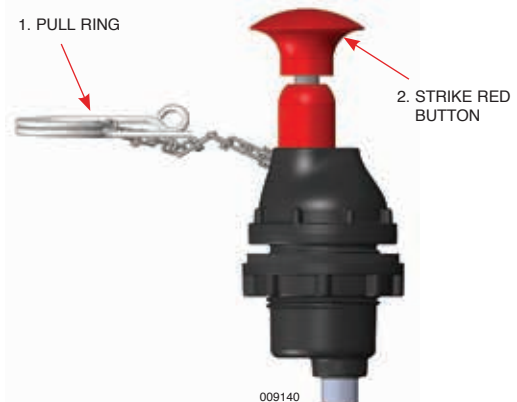

FIGURE 7-1
IMMEDIATE RELEASE OPTIONS

NOTES:

RECHARGE

Individuals responsible for recharging, inspecting, and maintaining a CHECKFIRE 110 System, must hold current ANSUL Certification from an ANSUL A-101 or LVS training program.

For continued protection, the CHECKFIRE 210 System and fire suppression system must be recharged immediately after activation.

Before performing the recharge steps, inspect the CHECKFIRE 210 Detection and Actuation System to determine cause of system release.

1. Remove power from system both external and internal as applicable.
2. Check all Electric Manual Actuators (EMAs) for evidence of operation and determine if visual inspection seal is intact. For EMAs needing reset and/or re-sealing complete the following:
 - a. Reset switch to normal position (pull button out)
 - b. Insert ring pin
 - c. Wait to seal until after system test
3. If optional pneumatic actuation is part of the system follow recharge instructions in the appropriate A-101 or LVS Design, Installation, Recharge, and Maintenance manual (latest edition).

LT-A-101-10/20/30 Manual (Part No. 24327)
LT-A-101-50/125/250 Manual (Part No. 427865)
LVS Manual (Part No. 427109)
4. Closely examine all Detection Circuit Cable, Linear Detector, and Spot Thermal Detectors for loose connectors and damage (cut, abraded, burnt, blackened, melted, deformed, etc.).
 - a. Inspect all Detection Circuit Cable for damage and replace if there are visible and mechanical signs of damage (brittleness, deformation, discoloration, etc.).

CAUTION

Failure to replace damaged cable can result in unintended system activation.

- b. If a fire event was the cause of discharge, all Linear Detector cables in the hazard area must be replaced; otherwise, inspect for damage and replace if damaged. **Note:** Splicing of Linear Detector cable is **not allowed**.
- c. If a fire event was the cause of discharge, all Spot Thermal Detectors and related cable installed in immediate area(s) of fire must be replaced. When subject to high temperatures, set-point drift and damage may occur that is not visible for field observation. (The “resettable” feature of the detector is for field-testing (with appropriate test equipment), not for resetting after a fire.) **Note:** Spot Thermal Detectors will be field-tested in step 10.

CAUTION

Failure to replace spot thermal detectors can result in system failure.

5. Closely examine all Release Circuit Cables for loose connectors and damage (cut, abraded, burnt, blackened, melted, deformed, etc.). Replace cables as needed.
6. Check and perform maintenance on each Electric-Pneumatic Actuator (Part No. 439569) (installed on each agent tank expellant gas cartridge): **Note:** If system was electrically operated all of the PADs should be actuated.
 - a. If attached, remove Release Circuit Drop Cable from Electric-Pneumatic Actuator.

CAUTION

When handling the PAD, always point actuating end away from yourself and others. On electrical initiation, PAD operates very quickly and a small brass disk forcefully separates from actuating end. Physical injury may occur from contact with the actuating pin and/or the detaching disk.

CAUTION

The Release Circuit Drop Cable with PAD must be removed from Electric-Pneumatic Actuator to retract actuator puncture pin. An actuated PAD can lock the Electric-Pneumatic Actuator puncture pin in the actuated position until removed from actuator.

- b. Confirm PAD o-ring is in place; if absent, check inside actuator and remove. (New PAD comes with new o-ring.) See Figure 8-1.

CAUTION

Failure to remove loose o-ring from inside actuator body can result in improper positioning of the PAD and incorrect system operation.

RECHARGE (Continued)

- c. Examine actuating end of PAD to determine if PAD has actuated. **Note:** Occasionally the actuating pin will pull back into the PAD. Inspect actuating end where pin extends. If pin is visible PAD has actuated. See Figure 8-2.
- d. If PAD actuated, remove PAD from the connector and discard. See Figure 8-1. **Do not install new PAD until testing is complete, see Step 10.** Find and discard small brass disk ejected from actuating end of PAD during release.
- e. If PAD has not actuated (system actuated with optional pneumatic manual actuator), refer to Five-Year PAD Replacement instructions, page 8-6, and replace if needed.



**FIGURE 8-1
 ACTUATED PAD**
 009242

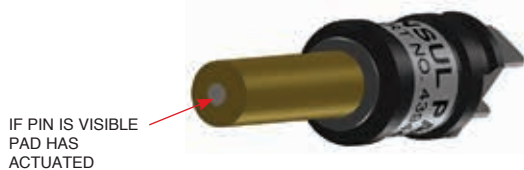

**FIGURE 8-2
 CHECK END OF PAD**
 009243

- f. If needed, remove 1/4 in. gas actuation hose(s). Loosen and slide base of Electric-Pneumatic Actuator sideways to remove from each expellant gas cartridge.

CAUTION

If Electric-Pneumatic Actuator is difficult to remove puncture pin is not fully retracted. Do not force.

- g. Disassemble actuator and inspect for damage. Using small wood dowel gently push puncture pin and spring out of body being careful not to bend puncture pin. Retain all parts for re-assembly. See Figure 8-3.



**FIGURE 8-3
 ELECTRIC-PNEUMATIC ACTUATOR
 RETAIN ALL PARTS FOR RE-ASSEMBLY**
 009244

- h. Inspect and replace all damaged components (o-rings, flat gaskets, etc.).
 - i. Lubricate all o-rings and gaskets with Dow Corning #4 (or equal) and reinstall. Include o-ring on PAD.
 - j. Replace flat gasket semi-annually.
 - k. Install spring on puncture pin and insert into body. Push down several times to confirm ease of movement.
 - l. Reassemble actuator.
 - m. Install actuator cap and pressure test using dry air or nitrogen.
7. Recharge the fire suppression system in accordance with the appropriate A-101 or LVS Design, Installation, Recharge and Maintenance manual (latest edition).
- | | |
|----------------------------|-------------------|
| LT-A-101-10/20/30 Manual | (Part No. 24327) |
| LT-A-101-50/125/250 Manual | (Part No. 427865) |
| LVS Manual | (Part No. 427109) |
8. After fire suppression system recharge is complete:
- a. Confirm puncture pin is completely retracted on the Electric-Pneumatic Actuator(s). See Figure 8-4.

! WARNING

Before attaching Electric-Pneumatic Actuator to expellant gas cartridge, **verify the cartridge is properly secured and confirm actuator puncture pin is in the completely retracted position.** If puncture pin is not completely retracted the cartridge seal can become damaged or pierced which can result in system actuation or serious personal injury or death.

RECHARGE (Continued)

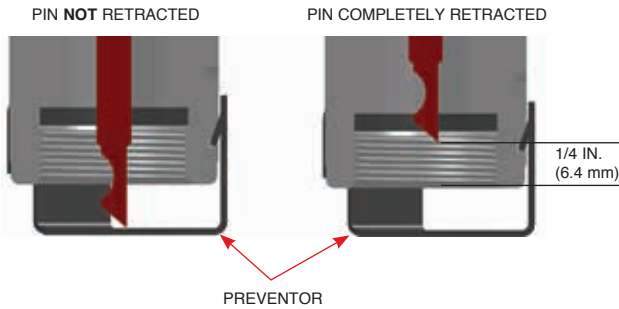

FIGURE 8-4
RETRACT ACTUATOR PIN
009220

- b. Re-install Electric-Pneumatic Actuator(s) on expellant gas cartridge(s). See Section 5 – Installation and Programming, page 5-11 and 5-12 for correct procedure.
9. Test system and place into service by completing all steps in Section 6 - Operational Test and Place in Service, prior to proceeding to Step 10.
10. Complete steps 1 – 4 in the Maintenance Section.
11. Confirm all system equipment has been properly serviced and recharged, and visual inspection seals are in place on all EMAs and Display Module.
12. Record date of recharge on tag and in permanent record file. Notify operating personnel system is back in service.

INSPECTION AND MAINTENANCE

To help ensure the CHECKFIRE 210 Detection and Actuation System will operate as intended, proper inspection and maintenance procedures must be performed at the specified intervals.

DAILY INSPECTIONS

The vehicle/equipment operator must check the system daily by visually verifying:

- Power LED is Green and steady-on with external/dual power or pulsing 1 x 3 seconds with internal power, see Figure 8-5
- All other LEDs are off (not steady-on or pulsing)
- Sounder is silent
- No apparent damage to any components

If any other conditions exist, contact the local Authorized ANSUL Distributor or a person who has been trained and authorized by Tyco Fire Protection Products to perform inspection and maintenance service on the CHECKFIRE 210 System.

WITH EXTERNAL/DUAL
POWER, LED IS GREEN
STEADY-ON

WITH INTERNAL
POWER, LED IS
PULSING GREEN
1 X 3 SECONDS



FIGURE 8-5
NORMAL CONDITION
009275

MAINTENANCE

To help ensure the system will operate as intended, maintenance shall be performed semi-annually or sooner, depending on the operating and/or environmental conditions. Maintenance should be performed by an Authorized ANSUL Distributor or a person who has been trained and authorized by Tyco Fire Protection Products to perform maintenance checks.

Visually inspect system to confirm it is adequate for the equipment hazard areas.

If system is displaying faults, go to Section 9 – Troubleshooting prior to continuing Maintenance.

1. Check condition of the CHECKFIRE 210 Display Module.
 - a. Confirm securely mounted, either in the CHECKFIRE 110/210 Mounting Bracket or surface mounted. Verify all fasteners are tight and display module enclosure nut is hand-tight.
 - b. If secured in bracket, check bracket for damage or wear to ratchet teeth.
 - c. Check display module for damage or undue wear.
2. Check condition of CHECKFIRE 210 Interface Control Module (ICM).
 - a. Confirm CHECKFIRE 210 Mounting Plate is securely mounted and CHECKFIRE ICM is securely affixed to Mounting Plate.
 - b. Confirm cable connections to ICM receptacles are tight (hand-tighten only). Push in and re-tighten to verify.
3. Check cable connectivity and integrity.
 - a. Confirm cable connections are tight (hand-tighten only). Push in and re-tighten to verify.
 - b. Inspect all cables and connections for wear, abrasion or other physical damage.
 - c. Confirm all cables are properly secured within 1 ft (0.3 m) on both sides of each connection and every 3 ft (0.9 m) along cable length.

MAINTENANCE (Continued)

4. Check integrity of each component.
 - a. Confirm Electric Manual Actuator (EMA) is:
 - Securely mounted
 - No damage, wear, or abrasions
 - Red strike button intact
 - Ring pin intact and in place
 - Rubber boot intact
 - Connector secure
 - Visual inspection seal intact
 - Bracket secure
 - b. Confirm Electric-Pneumatic Actuator is:
 - Securely mounted
 - All actuator components appropriately tightened
 - Release Circuit Drop Cable connection tight
 - 1/4 in. brass plugs securely tightened in pneumatic ports OR - if optional pneumatic actuation, 1/4 in. actuation hose fittings securely in place
 - c. Confirm Spot Thermal Detector is:
 - Securely mounted and heat shields in place
 - Proper location
 - Inspect for damage to face of detector
 - Verify tightness of the heat shield and retaining nut. Torque not to exceed 25 in-lb (2.82 N•m).
5. If optional Pneumatic Manual Actuator is part of system refer to appropriate system manual for inspection and maintenance instructions (latest edition):
 - LT-A-101-10/20/30 Manual (Part No. 24327)
 - LT-A-101-50/125/250 Manual (Part No. 427865)
 - LVS Manual (Part No. 427109)
6. If system includes optional pneumatic manual actuator(s), carefully remove the LT-10-R cartridge(s) from the pneumatic manual actuator(s), install shipping cap(s), and set aside in a safe location.
7. Check and perform maintenance on each Electric-Pneumatic Actuator (Part No. 439569) (installed on each agent tank expellant gas cartridge):
 - a. Remove power from system both external and internal as applicable.
 - b. If attached, remove Release Circuit Drop Cable from Electric-Pneumatic Actuator.

CAUTION

When handling the PAD, always point actuating end away from yourself and others. On electrical initiation, PAD operates very quickly and a small brass disk forcefully separates from actuating end. Physical injury may occur from contact with the actuating pin and/or the detaching disk.

- c. Check PAD and maintenance records for installation date of PAD to determine if PAD needs replacement. Refer to Five-Year PAD Replacement instructions, page 8-6.
- d. Confirm PAD o-ring is in place; if absent, check inside actuator and remove. (New PAD comes with new o-ring.) See Figure 8-7.

CAUTION

Failure to remove loose o-ring from inside actuator body can result in improper positioning of the PAD and incorrect system operation.

- e. Examine actuating end of PAD to determine if PAD has actuated.

Note: Occasionally the actuating pin will pull back into the PAD. Inspect actuating end where pin extends. If pin is visible, PAD has actuated. See Figure 8-8.
- f. If PAD actuated, remove PAD from the connector and discard. If possible, determine why PAD was actuated. **Do not install new PAD until testing is complete, see Step 9.** Find and discard small brass disk ejected from actuating end of PAD during release.



**FIGURE 8-7
CHECK PAD**
009246

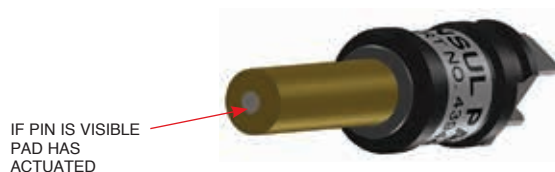

**FIGURE 8-8
CHECK END OF PAD**
009243

- g. If needed, remove 1/4 in. gas actuation hose(s). Loosen and slide base of Electric-Pneumatic Actuator sideways to remove from each expellant gas cartridge.

CAUTION

If Electric-Pneumatic Actuator is difficult to remove puncture pin is not fully retracted. Do not force.

MAINTENANCE (Continued)

- h. Disassemble actuator and inspect for damage. Using small wood dowel gently push puncture pin and spring out of body being careful not to bend puncture pin. Retain all parts for re-assembly. See Figure 8-9.



FIGURE 8-9
ELECTRIC-PNEUMATIC ACTUATOR
RETAIN ALL PARTS FOR RE-ASSEMBLY
009244

- i. Inspect and replace all damaged components (o-rings, flat gaskets, etc.).
- j. Lubricate all o-rings and gaskets with Dow Corning #4 (or equal) and reinstall. Include o-ring on PAD.
- k. Replace flat gasket semi-annually.
- l. Install spring on puncture pin and insert into body. Push down several times to confirm ease of movement.
- m. Reassemble actuator.
- n. Install actuator cap (if needed) and pressure test using dry air or nitrogen.
8. Re-install Electric-Pneumatic Actuator on expellant gas cartridge. See Section 5 – Installation and Programming, page 5-11 and 5-12 for correct procedure steps 1-4.
9. Test system and place into service by completing all steps in Section 6 - Operational Test and Place in Service, prior to proceeding to Step 11.
10. Internal Battery Inspection/Replacement:
- When using internal power only, internal battery must be replaced annually, after a discharge or when low power is indicated (i.e., Power LED pulses Amber 1 x 10 seconds). To inspect the battery remove battery cover and pull battery out of battery well. Review installation date on battery to determine if battery requires replacement (i.e., greater than 12 months).
 - When using dual power, internal battery must be replaced when there is a low power indication (i.e., Power LED pulses Amber 1 x 10 seconds) or battery life remaining is less than 25%. Percent of battery life remaining is listed in the header information of the Event History Log. To save or view the Event History Log review Section 5 – Installation and Programming, page 5-31, for manual download instructions or page 5-36 for viewing with the ANSUL CHECKFIRE 210 Programmer software.

- When replacing the battery module (e. g., during annual maintenance) the battery life indicator must be reset using the ICM or connect to a PC with the ANSUL CHECKFIRE 210 Programmer software.
 - a. Replace the battery module with a new/unused unit. Record the replacement date on the inside sticker of the battery compartment cover and on the battery itself.
 - b. Reset Battery Life Indicator:
ICM Instructions:
 - 1) Place the CHECKFIRE 210 System into isolate mode using the isolate switch on the side of the ICM. (Amber Isolate LED and sounder on the Display Module will quickly pulse 2 x 30 seconds.)
 - 2) Press and hold the programming button for more than five seconds then release.
 - 3) All programming LEDs pulse 3 times in one second to confirm battery life indicator is reset.
 - 4) Cancel isolate mode by returning the isolate switch to the normal position.

PC Instructions

When connected to the ANSUL CHECKFIRE 210 Programmer software, click the Reset button in the Battery Life Remaining section.

CAUTION

Performing a reset of the battery life indicator without installing a new/unused replacement battery module can result in faulty battery indications and unpredictable CHECKFIRE 210 System operation.

CAUTION

Contact your local waste disposal company for information concerning the correct disposal of lithium batteries.

11. For fire suppression system maintenance refer to appropriate system manual (latest edition)
- LT-A-101-10/20/30 Manual (Part No. 24327)
 - LT-A-101-50/125/250 Manual (Part No. 427865)
 - LVS Manual (Part No. 427109)
12. Confirm all system equipment has been properly serviced and recharged, and visual inspection seals are in place on all EMAs and CHECKFIRE 210 Display Module.
13. Record date of maintenance on tag and in permanent record file. Notify operating personnel system is back in service.

MAINTENANCE (Continued)

Five-Year PAD Replacement

1. The PAD (Protracting Actuation Device) must be replaced after being in-service for five years.
 - a. The in-service date must be recorded in installation and maintenance records and written on the PAD label with permanent marker at the time of installation. See Figure 8-10.
 - b. The PAD has a 10-year shelf life when stored in an environmentally stable location. The 5-year in-service life may not extend beyond the 10-year shelf life. The month and year of manufacture is printed on the label, see Figure 8-11.
 - c. For proper disposal, the PAD must be actuated before discarding. Actuate the PAD in a safe manner consistent with site safety policies.



FIGURE 8-10
WRITE DATE ON PAD
009169



FIGURE 8-11
PAD MANUFACTURING DATE
009247

⚠ CAUTION

When handling the PAD, always point actuating end away from yourself and others. On electrical initiation, PAD operates very quickly and a small brass disk forcefully separates from actuating end. Physical injury may occur from contact with the actuating pin and/or the detaching disk.

2. Write installation date on new PAD(s). DO NOT cover manufacturing date on label. See Figure 8-10. Do not install PAD(s) until testing is complete.
3. If needed, follow instructions in Section 5 – Installation and Programming, page 5-9, to complete re-installation of the Electric-Pneumatic Actuator.
4. Place in service by completing Table 6-6 – Placing CHECKFIRE 210 System in Service, pages 6-20 – 6-22 (Section 6 – Operational Test and Place in Service).
5. Record date of PAD replacement in a permanent record file. Notify operating personnel the system is back in service.

TABLE 8-1: EVENT HISTORY MESSAGES

1.	"System Reset"	25.	"Release Circuit Activated"
2.	"System All Clear"	26.	"Detection Input #1 Electric Manual Activation"
3.	"Self-Diagnostics Routine Failed"	27.	"Detection Input #2 Electric Manual Activation"
4.	"Audible Notification Silenced"	28.	"Detection Input #1 Initiated"
5.	"Audible Notification Silence Expired"	29.	"Detection Input #1 Initiation Cleared"
6.	"External Power Operation"	30.	"Detection Input #2 Initiated"
7.	"External Power Fault"	31.	"Detection Input #2 Initiation Cleared"
8.	"Internal Battery Operation"	32.	"\\"PUSH TO ACTIVATE\\" Button Pressed"
9.	"Internal Battery Fault"	33.	"Discharge Confirmed by Pressure Switch"
10.	"Battery Accumulator Reset"	34.	"Alarm Relay Activated"
11.	"System Powered Down"	35.	"Fault Relay Activated"
12.	"Release Circuit Ground Fault"	36.	"Shutdown Relay Activated"
13.	"Release Circuit Open Circuit Fault"	37.	"Alarm Relay Deactivated"
14.	"Release Circuit Fault"	38.	"Fault Relay Deactivated"
15.	"Release Circuit Fault Cleared"	39.	"Shutdown Relay Deactivated"
16.	"Detection Input #1 Ground Fault"	40.	"Isolate Switch Activated"
17.	"Detection Input #1 Open Circuit Fault"	41.	"Isolate Switch Deactivated"
18.	"Detection Input #1 Fault Cleared"	42.	"Configuration Has Been Modified"
19.	"Detection Input #2 Ground Fault"	43.	"History Erased"
20.	"Detection Input #2 Open Circuit Fault"	44.	"Display Fault"
21.	"Detection Input #2 Fault Cleared"	45.	"Display Fault Cleared"
22.	"Time Delay #1 Started"	46.	"Internal Hardware Fault, Replace ICM"
23.	"Time Delay #1 Restarted"	47.	"Firmware Upgrade"
24.	"Time Delay #2 Started"		

NOTES:

TROUBLESHOOTING

The following tables provide information on normal operating and fault condition indications for the CHECKFIRE 210 Detection and Actuation System. **For detailed circuit testing procedures, refer to Table 9-7 – Specific Circuit Testing Procedures.** When all faults are cleared, confirm proper operation of the entire CHECKFIRE 210 System by completing Section 6 – Operational Test and Place in Service.

TABLE 9-1: POWER LED INDICATIONS



<p>Normal Operating Condition – External/Dual Power Green Power LED is steady-on indicating a normal condition.</p> <p>System is monitoring all circuits and is ready to respond to a fault/alarm condition.</p>	<p>KEY TO DISPLAY MODULE INDICATIONS – IDENTIFY LEDs AS:</p>  <p>LED STEADY-ON (Red or Green) LED PULSING (Amber, Red or Green) LED OFF</p>
<p>NORMAL CONDITION EXTERNAL/DUAL POWER</p> <p>LED IS GREEN STEADY-ON</p>	 <p>009290</p>
<p>Normal Operating Condition - Internal Power Green Power LED pulses 1 x 3 seconds indicating normal operation on internal power supply.</p> <p>System is monitoring all circuits and is ready to respond to a fault/alarm condition.</p>	<p>NORMAL CONDITION INTERNAL POWER</p> <p>GREEN LED PULSES 1 X 3 SECONDS</p>  <p>009290</p>

TABLE 9-1: POWER LED INDICATIONS (Continued)

AMBER Power LED

Internal or External Power Fault

Amber Power LED and Sounder pulsing 1 x 10 seconds indicating power from the power source dropped below acceptable level causing a fault condition.

- Check Power Circuit Cable and Fused Power Circuit Cable for proper connections and for proper voltage
- Confirm fuse is good and installed correctly (See Section 5 – Installation and Programming, page 5-16 for correct removal and replacement of fuse.)
- Replace cables if unable to clear fault indication
- Check connection of the Battery Module to the ICM battery cable located under the battery compartment cover.
- Check and replace internal power Battery Module with a new/unused battery module. See Battery Replacement in Section 8 – Recharge, Inspection, and Maintenance, page 8-5.

INTERNAL/
EXTERNAL POWER
FAULT

AMBER LED AND
SOUNDER PULSE
1 X 10 SECONDS



Dual Power Fault

Amber Power LED pulsing 1 x 3 seconds indicating power from the external power source dropped below acceptable level causing a fault condition. When external power source drops below an acceptable level system automatically draws power from internal battery.

- Check Power Circuit Cable and Fused Power Circuit Cable for proper connections and for proper voltage
- Confirm fuse is good and installed correctly (See Section 5 – Installation and Programming, page 5-16 for correct removal and replacement of fuse.)
- Replace cables if unable to clear fault indication

DUAL POWER
FAULT

AMBER LED PULSES
1 X 3 SECONDS



For more information see TABLE 9-7: Specific Circuit Testing Procedures.

TABLE 9-2: RELEASE LED INDICATIONS



AMBER Release LED	RELEASE CIRCUIT FAULT	 The image shows the ANSUL CHECKFIRE 210 CONTROL SYSTEM display. The top right corner shows a green 'POWER UP' indicator. The center has 'DETECTION 1 2' and 'ISOLATE' buttons. The bottom left has 'DELAY RELEASE' and 'SHUTDOWN' buttons. The bottom right has a red 'PUSH TO ACTIVATE' button. An amber LED indicator is shown in the top left corner. The display is labeled '009290' at the bottom right.
<p>Amber Release LED and Sounder pulsing 1 x 10 seconds indicating Release Circuit fault.</p> <ul style="list-style-type: none">• Check Release Circuit Cables for an open circuit or a ground fault; replace cables as needed• Check connections• Indicates post release activated when combined with Shutdown LED and/or other LEDs. Check for activated or missing PAD(s); replace as needed following Section 8 – Recharge, Inspection, and Maintenance, page 8-1, for Recharge instructions.	AMBER LED AND SOUNDER PULSE 1 X 10 SECONDS	
RED Shutdown LED	POST RELEASE ACTIVATED MODE/ RELEASE CIRCUIT FAULT	 The image shows the ANSUL CHECKFIRE 210 CONTROL SYSTEM display. The top right corner shows a green 'POWER UP' indicator. The center has 'DETECTION 1 2' and 'ISOLATE' buttons. The bottom left has 'DELAY RELEASE' and 'SHUTDOWN' buttons. The bottom right has a red 'PUSH TO ACTIVATE' button. A red LED indicator is shown in the top left corner. The display is labeled '009290' at the bottom right.
<p>Red Shutdown LED, and Sounder pulsing 1 x 10 seconds indicating Post Release Activated Mode/Release Circuit Fault.</p> <ul style="list-style-type: none">• Indicates Post Release Activated System release, proceed to Section 8 – Recharge, Inspection, and Maintenance, page 8-1, for Recharge instructions.	RED LED AND SOUNDER PULSE 1 X 10 SECONDS	
For more information see TABLE 9-7: Specific Circuit Testing Procedures.		

TABLE 9-3: DETECTION LED INDICATIONS

AMBER Detection 1 and/or 2 LED

Applies to Detection Circuit #1 and/or #2.

Amber Detection Circuit #1 and/or #2 LED and Sounder pulsing 1 x 10 seconds indicating Detection Circuit fault.

- Check connections on the indicated circuit(s)
- Check Detection Circuit Cables for an open circuit or a ground fault; replace cables as needed
- Verify Linear Detector or Spot Thermal Detector continuity or ground fault condition. Replace as needed

**DETECTION CIRCUIT
 FAULT**

AMBER LED(s) AND
 SOUNDER PULSE
 1 X 10 SECONDS



RED Detection 1 and/or 2 LED

Applies to either Detection Circuit #1 or #2.

Red Detection Circuit #1 and/or #2 LED and Sounder pulsing 1 x 1 seconds indicating Detection Circuit alarm condition.

- Investigate alarm condition in hazard area
- Check for damaged or activated detectors
- Check for damaged cables
- Check connections on the indicated circuit(s)

**DETECTION CIRCUIT
 ALARM CONDITION**

RED LED(s) AND
 SOUNDER PULSE
 1 X 1 SECONDS



Red Detection Circuit #1 and/or #2 LED and Sounder pulsing 1 x 10 seconds indicating Detection Circuit alarm condition during Post Release Activated Mode. Refer to Section 8 – Recharge, Inspection, and Maintenance, page 8-1, for Recharge instructions.

- Investigate alarm condition in hazard area
- Check for damaged or activated detectors
- Check for damaged cables
- Check connections on the indicated circuit(s)

**DETECTION CIRCUIT
 ALARM CONDITION
 - DURING
 POST RELEASE
 ACTIVATED MODE**

RED LED(s) AND
 SOUNDER PULSE
 1 X 10 SECONDS



For more information see TABLE 9-7: Specific Circuit Testing Procedures.

TABLE 9-4: ISOLATE MODE

AMBER Isolate LED

Amber Isolate LED and Sounder pulsing quickly 2 x 30 seconds indicate CHECKFIRE 210 System is in ISOLATE MODE.

Placing the System in Isolate Mode minimizes occurrence of a false release during service or maintenance procedures on the protected vehicle/equipment.

CAUTION

When System is in Isolate Mode, the Release Circuit cannot be initiated by an automatic detection circuit input.

In the event of fire, manual actuation will bypass Isolate Mode for immediate release. To operate manually:

- Press “PUSH to Activate/ Alarm When Lit” button

Or

- Pull ring pin and operate RED Strike button on an EMA or a pneumatic manual actuator

Note: If a fault or alarm condition occurs while in Isolate Mode the condition will be displayed and the module will remain in Isolate Mode.

CAUTION

If an alarm condition has occurred in Isolate Mode, do not return the System to normal until cause of detection notification is found and cleared. Switching the Isolate switch to the normal position during an alarm condition results in an immediate start of the Time Delay sequences leading to a release.

ISOLATE MODE

AMBER LED AND
 SOUNDER PULSE
 2 X 30 SECONDS



009290

TABLE 9-5: MULTIPLE AMBER LED INDICATIONS

Amber Release, Detection 1 and 2, Power LEDs, and Sounder pulsing quickly 1 x 1 second indicates a loss of communication between Display Module and ICM processor.

1. Remove all power from the system, disconnect external power and internal power if used.
2. Reconnect power; if the system still shows the four amber LEDs, replace ICM with a new ICM.

Loss of communications can be confirmed by a review of the Event History Log for the message: Display Fault.

LOSS OF COMMUNICATION

AMBER LEDs AND
 SOUNDER PULSE
 1 X 1 SECOND



009290

TABLE 9-6: NO LED INDICATIONS

All LEDs - No Indication

- Confirm Display Cable is not damaged and connected to ICM
- Determine if power is available at the ICM by temporarily putting the System into programming mode using the programming button (press 3 x 1 second) under the battery cover. If LEDs illuminate when entering programming mode, the ICM has power (go to next bullet). If the LEDs do not illuminate, then the System does not have power or ICM has an internal hardware fault; complete the following steps:
 1. Check connection of Battery Module to ICM battery cable located under the Battery Compartment Cover.
 2. Replace Battery Module with a new/unused battery module. See Battery Replacement in Section 8 – Recharge, Inspection, and Maintenance, page 8-5.
 3. Check external power connections, fuse, and cables, if utilized, for damage.
 4. Check external power supply for proper voltage, if connected.
 5. If proper voltage is verified at the ICM, and Power LED remains off, check display cable connections between display module and ICM.
- If the ICM has power, there is loss of communication between Display Module and ICM
 1. Remove all power from the system, disconnect external power and internal power if used,
 2. Reconnect power; if the system still shows no indication, replace Display Module with a new display module.
 3. If new Display Module still has no LED indication, replace the ICM with a new ICM.



009290

For more information see TABLE 9-7: Specific Circuit Testing Procedures.

TABLE 9-7: SPECIFIC CIRCUIT TESTING PROCEDURES

General Instructions

If faults are indicated on the CHECKFIRE 210 Display Module, test the connecting cables and end of circuit devices (EMAs, EOL Device, branch terminators, PADs, etc.), for proper connection to the system.

Before testing specific circuits, confirm completion of a thorough visual inspection. Inspect all cables for damage and replace if there are visible and/or mechanical signs of damage (brittleness, deformation, discoloration, etc.). Test all connections for loose or disassembled connectors.

Note: Remove power from system before replacing components.

Note: Once all faults are cleared, confirm proper operation of the entire CHECKFIRE 210 System by completing Section 6 – Operational Test and Place in Service.

If faults cannot be cleared, test each circuit and cable individually with the following procedures.

Power Circuit

If Power LED is showing no indication for more than 10 seconds check the connection of the Display Module to the ICM as well as all power connections.

Internal Power Only: If Power LED is pulsing AMBER 1 x 10 seconds and only using internal power this indicates the Battery Module is below an acceptable level.

- Inspect battery cable on ICM for damage
- Replace with a new/unused battery module

External / Dual Power: If Power LED is pulsing AMBER 1 x 3 seconds (dual power) or 1 x 10 seconds (external power only), use the following steps to troubleshoot the external power circuit.

Required Test Equipment

- New Fuse (3 amp inline ATO/ATC blade style automotive fuse)
- Digital Multimeter

1. Disconnect Power Circuit Cable at the ICM (green receptacle). Use the Digital Multimeter to confirm proper voltage is available at the end of the Power Circuit Cable. If voltage on Power Circuit Cable is correct, there is an internal problem and the CHECKFIRE 210 ICM must be replaced.

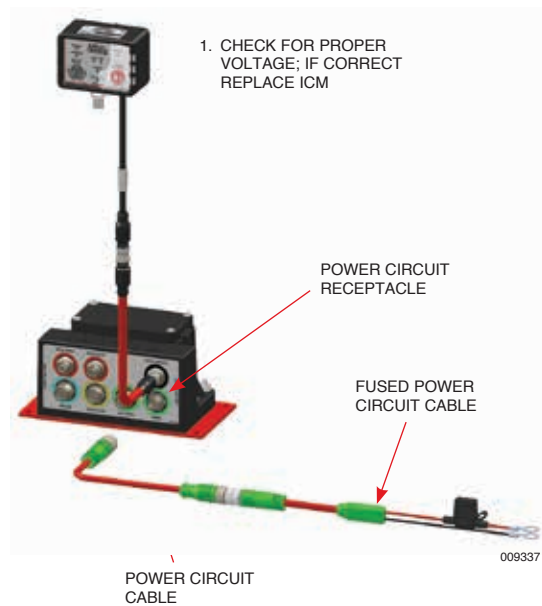

TABLE 9-7: SPECIFIC CIRCUIT TESTING PROCEDURES (Continued)

Power Circuit (Continued)

2. If voltage on Power Circuit Cable is not correct, use the Digital Multimeter to check for proper voltage at the equipment power source (battery).
 - a. If voltage is correct move to step 3.
 - b. If power source voltage is incorrect or indicates no power, contact equipment service personnel to correct. When voltage is restored reconnect entire power circuit to see if power fault clears. If fault does not clear return to step one.
3. Check fuse in the Fused Power Circuit Cable connected to equipment power source. If needed replace fuse following instructions in Section 5 – Installation and Programming, page 5-16 (step 5).
4. After confirming correct voltage at the power source and a good fuse, disconnect Fused Power Circuit Cable connector from power circuit and check for proper voltage with the Digital Multimeter. If voltage on Fused Power Circuit Cable is correct, the cable is functioning properly. If voltage is incorrect the Fused Power Circuit Cable must be replaced.
5. After confirming correct voltage at end of Fused Power Circuit Cable continue checking the remaining power circuit at each set of connectors for proper voltage from the power source. Replace non-functioning cable with an identical new part.

2. CONFIRM CORRECT VOLTAGE AT POWER SOURCE

3. CHECK FUSE, IF NEEDED REPLACE

FOLLOW SECTION 5 – INSTALLATION INSTRUCTIONS TO REPLACE FUSE



4. CONFIRM VOLTAGE AT CONNECTOR



5. CONFIRM VOLTAGE AT EACH SET OF CONNECTORS

6. After replacing non-functioning cable and confirming correct voltage through entire power circuit, reconnect to ICM. Power LED returns to GREEN steady-on.

If all faults are clear, verify proper operation of the CHECKFIRE 210 System by completing Section 6 – Operational Test and Place in Service.

6. CONFIRM CORRECT VOLTAGE THROUGH ENTIRE CIRCUIT AND RECONNECT

Note: Specific jurisdictions or customer procedures may require documentation of all components replaced. Keep a record of all changes to the system as required.

TABLE 9-7: SPECIFIC CIRCUIT TESTING PROCEDURES (Continued)

Release Circuit

If Release LED is pulsing AMBER indicating a release circuit fault and cannot be cleared check release circuit cable.

Required Test Equipment (Confirm test equipment is new and functioning properly)

- 2 - Release Circuit Terminators (Part No. 439436)
- Release Circuit Test Plug(s) (Part No. 440912) – one for each PAD

1. Power down system.
2. Replace all PADs with Release Circuit Test Plugs.
3. Power up system.
4. If fault clears, there is at least one faulty PAD. Repeat above steps (1- 3) for each PAD except at step 2 replace 1 Release Circuit Test Plug with a PAD one at a time to determine the faulty PAD.
5. If fault does not clear, disconnect Release Circuit Cable at the blue ICM release receptacle. Install Release Circuit Terminator directly to the receptacle on the ICM. If Release LED continues pulsing AMBER, there is an internal problem and the CHECKFIRE 210 ICM must be replaced.

⚠ CAUTION

When handling the PAD, always point actuating end away from yourself and others. On electrical initiation, PAD operates very quickly and a small brass disk forcefully separates from actuating end. Physical injury may occur from contact with the actuating pin and/or the detaching disk.

1. POWER DOWN
2. REPLACE ALL PADS WITH TEST PLUGS
3. POWER UP
4. IF FAULT CLEARS, CHECK FOR FAULTY PAD.



5. IF FAULT DOES NOT CLEAR, INSTALL TERMINATOR; IF FAULT CONTINUES, REPLACE ICM

RELEASE CIRCUIT RECEPTACLE, INSTALL TERMINATOR



TABLE 9-7: SPECIFIC CIRCUIT TESTING PROCEDURES (Continued)

Release Circuit (Continued)

6. If Release Circuit fault clears, the ICM is functioning properly and the fault is in the cabling or connectors. Re-install complete release circuit to the ICM Receptacle. Reset to Normal: Press and hold “DELAY/Reset/Silence” button for 3 seconds; Green and Red LEDs are steady-on for 1 second; then Amber LEDs are steady-on for 1 second; at end sounder quickly pulses 3 times.
7. If Release Circuit fault does not clear, continue testing the release circuit at each set of connectors starting at the next connection point from the ICM. Separate connectors and install Release Circuit Terminator at the end of the cable connected to the ICM. If fault does not clear, replace non-functioning component with an identical new part and retest. If fault clears, part is good; re-install and move to next set of connectors. **Note: Be sure to add only one additional component (cable, tee, etc.) at a time to help identify the specific part causing the fault.**
8. At a Release Circuit Tee remember to first check the main trunk connector leading to the tee; then re-connect to check the tee. Install a Detection Circuit Terminator on each side of tee. If fault clears tee is good. If fault does not clear replace tee.

6. IF FAULT CLEARS, RECONNECT AND RESET TO NORMAL

7. IF FAULT CONTINUES, TEST EACH CONNECTION, REPLACE COMPONENTS AS NEEDED

8. AT TEE, TEST MAIN TRUNK CONNECTION FIRST

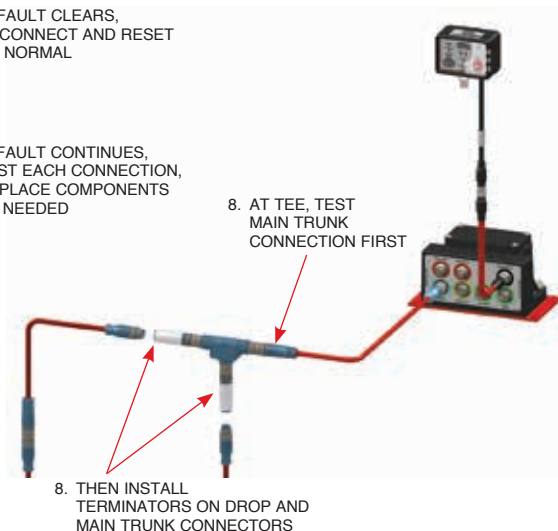

8. THEN INSTALL TERMINATORS ON DROP AND MAIN TRUNK CONNECTORS

9. After checking a Release Circuit Tee, continue testing drop line to the end of the Release Circuit Drop Cable.
10. Test Release Circuit Drop Cable using a Release Circuit Test Plug. If the Release Circuit Drop Cable causes a fault, replace it with an identical new part and retest.

9. AFTER TEE, CONTINUE TESTING DROP

10. IF DROP CABLE CAUSES A FAULT, REPLACE WITH NEW PART AND RETEST

RELEASE CIRCUIT TEST PLUG



TABLE 9-7: SPECIFIC CIRCUIT TESTING PROCEDURES (Continued)

Release Circuit (Continued)

11. After drop line is clear, return to the last connection that was good and continue testing the main trunk and any drop lines in the same manner until release circuit fault is clear.

When all faults are clear, verify proper operation of the CHECKFIRE 210 System by completing Section 6 – Operational Test and Place in Service.

11. AFTER DROP IS CLEAR, CONTINUE TESTING IN SAME MANNER UNTIL ENTIRE CIRCUIT IS CLEAR

Note: Specific jurisdictions or customer procedures may require documentation of all components replaced. Keep a record of all changes to the system as required.

Detection Circuit #1 and/or #2

If Detection Circuit #1 LED is pulsing AMBER and cannot be cleared check detection circuit #1 cable. Detection Circuit #2 is checked in a similar manner as the one described below, but should be investigated separately to avoid confusion.

Required Test Equipment (Confirm test equipment is new and functioning properly)

- Detection Circuit EOL Device (Part No. 439396)
- Detection Circuit Tester (DCT) (Part No. 440097) - set to "Normal" position
- Detection Circuit Branch Terminator (Part No. 439398)

1. Prior to testing the circuit, put system in Isolate Mode using the Isolate switch on the side of the ICM.
2. Disconnect Detection Circuit #1 Cable (and #2 if part of system) at the ICM receptacle. Install EOL Device or DCT on the ICM receptacle. If Detection Circuit #1 LED continues pulsing AMBER, there is an internal problem and the CHECKFIRE 210 ICM must be replaced.

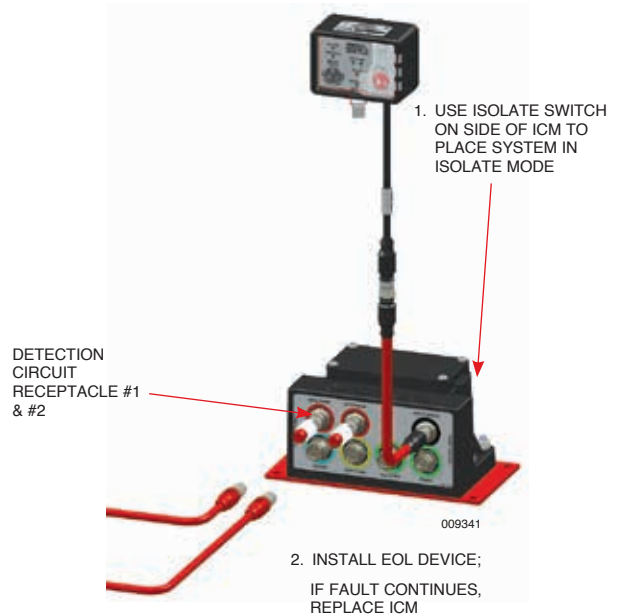

3. If Detection Circuit #1 fault clears, the ICM is functioning properly. Re-install complete detection circuit to the ICM detection circuit receptacle.

Reset to Normal: Press and hold "DELAY/Reset/Silence" button for 3 seconds; Green and Red LEDs are steady-on for 1 second; then Amber LEDs are steady-on for 1 second; at end sounder quickly pulses 3 times.

3. IF FAULT CLEARS, RECONNECT AND RESET TO NORMAL

TABLE 9-7: SPECIFIC CIRCUIT TESTING PROCEDURES (Continued)

Detection Circuit (Continued)

4. If Detection Circuit #1 fault does not clear, continue testing the detection circuit at each set of connectors starting at the next connection point from the ICM. Separate connectors and install EOL Device or DCT at the end of the cable connected to the ICM. If fault does not clear, replace non-functioning component with an identical new part and retest. If fault clears part is good; re-install and move to next set of connectors. **Note: Be sure to add only one new component (cable, tee, EMA, etc.) at a time to help identify the specific part causing the fault.**
5. At a Detection Circuit Tee remember to first check the main trunk connector leading to the tee, then re-connect to check the tee. Install a Detection Circuit Branch Terminator on branch side of tee, and the EOL Device or DCT on main trunk side. If fault clears tee is good; if fault does not clear replace tee.

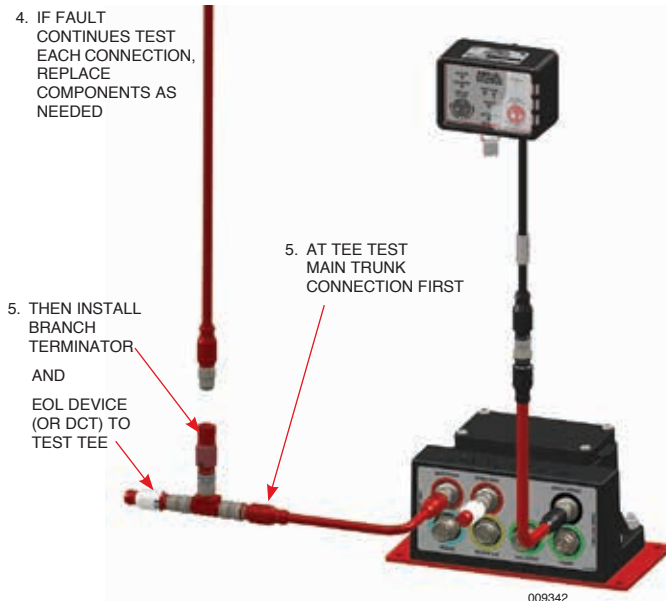

6. After checking a Detection Circuit Tee, continue testing components to the end of the branch line.
 - If a non-functioning component is found and replaced on a branch line, reconnect the complete detection circuit to determine if that is the only fault in the circuit.
 - If reconnecting the remaining detection circuit causes a fault, return to the last connection that was good and continue testing the main trunk and any branch lines in the same manner until detection circuit fault clears.
 - Cancel Isolate mode by returning the Isolate switch to the normal position.
 - If all faults are clear, verify proper operation of the CHECKFIRE 210 System by completing Section 6 – Operational Test and Place in Service.

6. IF FAULT IS CORRECTED IN BRANCH LINE, RECONNECT ENTIRE CIRCUIT;
 - IF FAULT OCCURS, CONTINUE TESTING CIRCUIT FROM LAST GOOD CONNECTION UNTIL FAULT CLEARS











When Detection Circuit #2 is part of the system, troubleshoot and correct faults on Detection Circuit #2 in a similar manner to those described above.

Note: Specific jurisdictions or customer procedures may require documentation of all components replaced. Keep a record of all changes to the system as required.

COMPONENT INDEX

<u>Part No.</u>	<u>Description</u>	<u>Part No.</u>	<u>Description</u>
System Components		Display Circuit Cables and Fittings	
439560	Display Module, CHECKFIRE 210	439452	Cable, Display - 2 ft (0.61)
439564	Mounting Bracket, CHECKFIRE 110/210	439454	Cable, Display - 5 ft (1.53)
439561	Interface Control Module (ICM), CHECKFIRE 210	439456	Cable, Display - 10 ft (3.05)
439569	Electric-Pneumatic Actuator (normally supplied with agent tanks)	439458	Cable, Display - 20 ft (6.10)
439400	Electric Manual Actuator (EMA)	439460	Cable, Display - 30 ft (9.15)
440537	Electric Manual Actuator Bracket	439462	Cable, Display - 50 ft (15.24)
Detection Circuit Cables and Fittings		439449	Connector, Bulkhead, Display Cable
439384	Cable, Detection Circuit - 2 ft (0.61 m)	Relay #1 & #2 Circuit Cable	
439386	Cable, Detection Circuit - 5 ft (1.53 m)	439466	Cable, Relay Cable-Leads, 3 ft (0.91)
439388	Cable, Detection Circuit - 10 ft (3.05 m)	440410	Cable, Backup Power/Relay Circuit, 2 ft (0.61 m)
439390	Cable, Detection Circuit - 20 ft (6.10 m)	440413	Cable, Backup Power/Relay Circuit, 5 ft (1.53 m)
440759	Cable, Detection Circuit - 30 ft (9.15 m)	439482	Cable, Backup Power/Relay Circuit, 10 ft (3.05 m)
440762	Cable, Detection Circuit - 50 ft (15.24 m)	440416	Cable, Backup Power/Relay Circuit, 20 ft (6.10 m)
439394	Connector, Tee, Detection Circuit (MxFxF)	Auxiliary Output Circuit Cable	
439396	Connector, EOL Device, Detection Circuit	439450	Cable, Auxiliary Power Output Circuit, 3 ft (0.91)
439398	Connector, Branch Terminator, Detection Circuit	Accessory Equipment	
439404	Connector, Bulkhead, Detection Circuit	440352	ICM Battery Module, CHECKFIRE 210
Linear Detector		▶ 438280	Spot Thermal Detector, 250° F (121° C)
▶ 439406	Linear Detector - 2 ft (0.61 m)	438281	Spot Thermal Detector, 350° F (177° C)
439478	Linear Detector - 5 ft (1.53 m)	▶ 440905	Spot Thermal Detector Bracket and Heat Shield
439480	Linear Detector - 10 ft (3.05 m)	▶ 440389	Discharge Pressure Switch
439408	Linear Detector - 20 ft (6.10 m)	440737	Double-Loop Cable Ties (Pkg. of 50)
439410	Linear Detector - 30 ft (9.15 m)	56692	Rubber Sleeve (Pkg. of 20)
▶ 440765	Linear Detector - 50 ft (15.24 m)	440798	Label Package
Release Circuit Cables and Fittings		440097	Detection Circuit Tester (DCT)
439418	Cable, Release Circuit - 2 ft (0.61 m)	441021	Release Circuit Tester (RCT)
439420	Cable, Release Circuit - 5 ft (1.53 m)	440912	Release Circuit Test Plug (Pkg. of 3)
439422	Cable, Release Circuit - 10 ft (3.05 m)	440768	Label, Branch Circuit (Pkg. of 10)
439424	Cable, Release Circuit - 20 ft (6.10 m)	440082	Guard Door, Display Module
439426	Cable, Release Circuit - 30 ft (9.15 m)	440083	Enclosure Nut, Display Module
439428	Cable, Release Circuit - 50 ft (15.24 m)	439567	Battery Cover, Interface Control Module (ICM)
439430	Cable, Release Circuit Drop - 30 in. (0.77 m)	439568	Mounting Plate, Interface Control Module (ICM)
439432	Cable, Release Circuit Drop - 38 in. (0.97 m)	440489	Receptacle Cap, Female, Detection Circuit #2 (Pkg. of 5)
439434	Connector, Tee, Release Circuit (MxFxF)	440490	Receptacle Cap, Female, Relay #1 and #2 or Aux. Output (Pkg. of 5)
439436	Connector, Release Circuit Terminator	440491	Receptacle Cap, Male, Power (Pkg. of 5)
439405	Connector, Bulkhead, Release and Power Circuits	440179	O-ring, Interface Control Module (ICM) (Pkg. of 5)
439448	Protracting Actuation Device (PAD), w/Spade Connectors		
Power Circuit Cables and Fittings			
439438	Cable, Power Circuit - 2 ft (0.61 m)		
439440	Cable, Power Circuit - 5 ft (1.53 m)		
439442	Cable, Power Circuit - 10 ft (3.05 m)		
439444	Cable, Power Circuit - 20 ft (6.10 m)		
439446	Cable, Power Circuit - 30 ft (9.15 m)		
440187	Cable, Power Circuit - 50 ft (15.24 m)		
439405	Connector, Bulkhead, Release and Power Circuits		
439492	Cable, Fused Power Circuit, (w/Inline Fuse Holder) - 3 ft (0.91 m)		

CABLE AND BULKHEAD DIMENSIONS

Cable Type	Largest Diameter on Connector		Cable Diameter		Hole Size to Pass Connector Through		Images
	in.	(mm)	in.	(mm)	in.	(mm)	
Linear Detector	0.64	(16.3)	0.130 0.172	(3.30) (4.37)	11/16	(17.5)	 009157
Detection Circuit Cable	0.64	(16.3)	0.300	(7.62)	11/16	(17.5)	 009158
Release Circuit Cable	0.75	(19.1)	0.300	(7.62)	3/4	(19.1)	 009163
Power Circuit Cable	0.75	(19.1)	0.300	(7.62)	3/4	(19.1)	 009172
I/O BUS, CANbus, and Display Cable	0.64	(16.3)	0.385	(9.78)	11/16	(17.5)	 009276
Backup Power/Relay Circuit Cable	0.75	(19.1)	0.295	(7.50)	3/4	(19.1)	 009282
Bulkhead Type	Maximum Panel Thickness		Overall Bulkhead Length		Panel Mounting Hole Size		Images
Detection Circuit Bulkhead Connector (Includes Linear Detector)	3/8	(9.5)	1 7/8	(47.6)	5/8	(15.9)	 009159
I/O BUS, CANbus, and Display Cable Bulkhead Connector	3/8	(9.5)	1 7/8	(47.6)	5/8	(15.9)	 009159
Release & Power Circuit Bulkhead Connector	1	(25)	2 7/16	(61.9)	21/32	(16.7)	 009166
Backup Power/Relay Circuit Bulkhead Connector	1	(25)	2 7/16	(61.9)	21/32	(16.7)	 009166

LINEAR DETECTOR FLUID RESISTANCE CAPABILITY

Resistance Rating Key:

G = GOOD

L = LIMITED

C = CONDITIONAL (Service conditions must be outlined to Tyco Fire Protection Products for approval of cable suitability for applications.)

U = UNACCEPTABLE (Not to be used)

Agent	Rating	Agent	Rating	Agent	Rating
Acetate Solvents, Crude	U	Diesel Oil, Light	L	Naphtha	C
Acetate Solvents, Pure	U	Ethers	U	Naphthalene	U
Acetic Acid, Dilute (20%)	U	Ethyl Acetate	U	Nickel Chloride	G
Acetic Acid, Glacial	U	Ethyl Alcohol	C	Nickel Sulfate	G
Acetone	U	Ethyl Chloride	U	Nitric Acid, 10%	L
Air	G	Ethylene Dichloride	U	Nitric Acid, 70%	U
Alcohols	C	Ethylene Glycol	L	Nitrobenzene	U
Aluminum Chloride	G	Ferric Chloride	G	Oleic Acid	C
Aluminum Fluoride	G	Ferric Sulfate	G	Oleum Spirits	U
Aluminum Sulfate	G	Ferrous Salt Solutions	G	Perchloroethylene	C
Ammonia Liquid (Anhydrous)	U	Formaldehyde	L	Picric Acid, Molten	U
Ammonia, Chloride	G	Formic Acid	L	Picric Acid, Solution	U
Ammonium Hydroxide	L	Fuel Oil	L	Potassium Chloride	G
Ammonium Nitrate	G	Furfural	U	Potassium Cyanide	G
Ammonium Phosphate	G	Gasoline	C	Potassium Hydroxide	C
Ammonium Sulfate	G	Glycerine, Glycerol	L	Potassium Sulfate	G
Amyl Acetate	U	Grease, Petro	L	Soda Ash Sodium Carbonate	G
Amyl Alcohol	L	Heptane	C	Sodium Bisulfate	G
Asphalt	C	Hexane	L	Sodium Chloride	G
Barium Chloride	G	Hydraulic Fluids & Lubricating Oils,		Sodium Cyanide	G
Barium Hydroxide	G	Straight Petroleum Base	L	Sodium Hydroxide	C
Barium Sulfide	G	Water and Petroleum Oil		Sodium Hypochlorite	C
Benzene, Benzol	C	Emulsion (FR)	L	Sodium Nitrate	G
Benzene (Petroleum Ether)	C	Water and Glycol Solution	L	Sodium Peroxide	C
Benzene (Petroleum Naphtha)	C	Straight Phosphate-Ester (FR)	L	Sodium Phosphate	G
Borax	L	Silicone Oils	L	Sodium Silicate	G
Boric Acid	L	Hydrobromic Acid	U	Sodium Sulfate	G
Bromine	U	Hydrochloric Acid, Cold	C	Sodium Sulfide	C
Butyl Acetate	U	Hydrochloric Acid, Hot	U	Sodium Thiosulfate, "Hypo"	G
Butyl Alcohol, Butanol	L	Hydrocyanic Acid	C	Soybean Oil	L
Calcium Bisulfite	L	Hydrofluoric Acid, Cold	C	Stannic Chloride	G
Calcium Chloride	G	Hydrofluoric Acid, Hot	C	Stearic Acid	L
Calcium Hydroxide	G	Hydrogen Peroxide (Dilute)	G	Sulfur Dioxide	C
Calcium Hypochlorite	L	Hydrogen Peroxide (Concentrated)	C	Sulfur Trioxide	C
Carbolic Acid Phenol	C	Hydrogen Sulfide	C	Sulfuric Acid, 10%, Cold	L
Carbon Dioxide	G	Kerosene	L	Sulfuric Acid, 10%, Hot	L
Carbon Disulfide	U	Lacquer Solvents	U	Sulfuric Acid, 75%, Cold	L
Carbon Monoxide, Hot	U	Lactic Acid	C	Sulfuric Acid, 75%, Hot	L
Carbon Tetrachloride	L	Linseed Oil	L	Sulfuric Acid, 95%, Cold	U
Carbonic Acid	G	Magnesium Chloride	G	Sulfuric Acid, 95%, Hot	U
Castor Oil	C	Magnesium Hydroxide	G	Sulfuric Acid, Fuming	U
Chlorinated Solvents	C	Magnesium Sulfate	G	Sulfurous Acid	L
Chlorine, Dry	U	Mercuric Chloride	U	Tannic Acid	G
Chlorine, Wet	U	Mercury	L	Tartaric Acid	G
Chloroacetic Acid	U	Methyl Alcohol, Methanol	L	Toluene	U
Chloroform	U	Methyl Chloride	U	Trichloroethylene	U
Chlorosulphonic Acid	U	Methyl Ethyl Ketone	U	Turpentine	L
Chromic Acid	U	Methyl Isopropyl-Keytone	U	Varnish	U
Citric Acid	L	Mineral Oil	L	Xylene	U
Copper Chloride	G			Zinc Chloride	L
Copper (II) Sulfate	G			Zinc Sulfate	G
Creosote	U				

CHEMICAL RESISTANT CHART

(For Linear Detector material)

This chemical resistance chart cannot predict the effect on the outer covering to complex chemical mixtures. The appropriate chemical resistance tests using a representative sample of the chemical(s) or a trial installation of the Linear Detector should be performed to determine acceptable product performance.

Chemical	Percent Concentration	Maximum Temperature	
		°F	(°C)
Acids			
Hydrochloric	37	302	(150)
Hydrofluoric	50	302	(150)
Nitric	65	151	(66)
Phosphoric	85	302	(150)
Bases			
Ammonium hydroxide	30	302	(150)
Potassium hydroxide	30	250	(121)
Sodium hydroxide	50	250	(121)
Sodium hypochlorite	5 - stabilized at pH 12	302	(150)
Hydrocarbons			
n-Hexane	100	302	(150)
Toluene	100	151	(66)
Alcohols and Ethers			
Methanol	100	149	(65)
Ethanol	100	57	(14)
Organic Acids, Esters and Ketones			
Acetic acid	100	>221	(>100)
	50	>250	(>121)
Acetone	100	151	(66)
Acetophenone	100	122	(50)
Ethyl Acetate	100	122	(50)

Chemical	Percent Concentration	Maximum Temperature	
		°F	(°C)
Classic Polymer Solvents			
Dimethyl formamide	100	122	(50)
Dimethyl sulphoxide	100	212	(>100)
N-Methylpyrrolidone	100	77	(25)
Halogenated Solvents			
Chlorobenzene	100	151	(66)
Chloroform	100	Not resistant	
Amines and Nitriles			
Acetonitrile	100	>212	(>100)
Aniline	100	212	(100)
Dimethyl amine	100	77	(25)
Peroxides			
Hydrogen peroxide	30	>190	(>88)
Automotive Fluids			
Crude Oils	100	302	(150)
Dexron II (gear oil)	100	302	(150)
Gasoline	100	302	(150)
Diesel Fuels	100	302	(150)
Mineral Oil	100	302	(150)